



Installation and Operating Manual

Alarm- and protection device Leak-water detector

GEWAS 191 AN / N / ANOV



-  Please read these instructions carefully before use!
-  Please consider the safety instructions!
-  Please keep for future reference!



WEEE-Reg.-Nr. DE 93889386

Index

1	INTENDED USE	2
2	GENERAL NOTE	FEHLER! TEXTMARKE NICHT DEFINIERT.
3	SCOPE OF SUPPLY	FEHLER! TEXTMARKE NICHT DEFINIERT.
4	SAFETY	3
4.1	SAFETY SIGNS AND SYMBOLS	3
4.2	SAFETY REQUIREMENTS	3
5	INSTALLATION AND COMMISSIONING	4
5.1	INSTALLATION OF THE SOLENOID VALVE	4
5.2	INSTALLATION OF THE CONTROL UNIT AND THE WATER SENSOR	4
6	FUNCTION	5
7	ALARM UND OPERATING SIGNALS	5
8	WHAT TO DO IN CASE OF ALARM	5
9	OPERATING AND MAINTENANCE ADVICES	6
10	DECOMMISSIONING, RESHIPMENT AND DISPOSAL	6
10.1	DECOMMISSIONING	6
10.2	RESHIPMENT AND DISPOSAL	6
11	SPECIFICATION	7

1 Intended use

The GEWAS 191 N / AN / ANOV is an alarm and protection device.

Depending on the device variant, no solenoid valve or a solenoid valve (plastic or brass) for water feed mounting or a brass solenoid valve for pipe mounting is included in the scope of delivery:

Solenoid valves for manual mounting: The solenoid valve must be mounted tight between a water tap with $\frac{3}{4}$ " thread and the machine hose.
In principle, the assembly can be carried out by the end user.

Solenoid valves for pipe mounting: These solenoid valves are designed for direct mounting in pipes.
The installation must be carried out by a specialist (plumber, ...).

If a water film is detected at the sensor, the solenoid valve (GEWAS 191 N / AN) will be closed and the unit warns with an intense signal tone.

The GEWAS 191 AN and GEWAS 191 ANOV also switches off the device (e.g. washing machine, dish washer) connected to the control device.

To be able to operate safely the device has to be checked for its correct function at regular basis. (please refer to Operating and maintenance advices of this document).

Operation is only allowed with the defined scope of supply or with original accessory for this device.

Application range:

- Alarm and protection device for prevention of water damage
- Observation of devices and machines with water-connection

Another or a further use is considered as not being in compliance with the intended use.
The operator of the device is liable for any resulting damage or harm.



Follow the installation description, when connecting to water supply.

2 General Note

Read this document carefully and get used to the operation of the device before you use it. Keep this document within easy reach near the device for consulting in case of doubt.

3 Safety

3.1 Safety signs and symbols

Warnings are labelled in this document with the followings signs:







Caution! This symbol warns of imminent danger, death, serious injuries and significant damage to property at non-observance.



Note! This symbol point out processes which can indirectly influence operation or provoke unforeseen reactions at non-observance.

3.2 Safety requirements

This device has been designed and tested in accordance with the safety regulations for electronic devices. However, its trouble-free operation and reliability cannot be guaranteed unless the standard safety measures and special safety advises given in this manual will be adhered to when using the device.

1. Trouble-free operation and reliability of the device can only be guaranteed if the device is not subjected to any other climatic conditions than those stated under "specification".
2. Do not modify the device and do not operate with other components than allowed for this device.
3. Make sure to observe the standard regulations and safety instructions for electric, heavy and weak current plants, in particular the national safety regulations (e.g. VDE0100).
4.  When there is a risk whatsoever involved in running it, the device has to be switched off immediately and to be marked accordingly to avoid re-starting it.
Operator safety may be a risk when the device:
 - has visible damages
 - is not working as specified
 - has been stored under unsuitable conditions for a longer time
 - Technical changes have been made to the device
 In case of doubt, please return device to manufacturer for repair or maintenance.
5.  **Warning:** Do not use this product as safety or emergency stop devices, or in any other application were failure of the product could result in personal injury or material damage.
Failure to comply with these instructions could result in death or serious injury and material damage.
6.  This device must not be used in an explosive environment.
This device is not designed for medical requirements!
7.  Due to the operation on water net there is the risk of electrical hazard in case of erroneous water installation. The device therefore is only allowed to be operated with suitable means of protection (e.g. residual current circuit-breaker with current $\leq 30\text{mA}$)
8.  The integrated mains socket is protected against touch, however, in unfortunate constellation there may be the risk of electrical hazard, e.g. when having kids in household, using a wire or a metal device, narrow enough. The device therefore is only allowed to be operated with suitable means of protection (e.g. child protection accessory and residual current circuit-breaker with current $\leq 30\text{mA}$)
9. This appliance can be used by children aged from 8 years and above and persons with reduced physical, sensory or mental capabilities or lack of experience and knowledge if they have been given supervision or instruction concerning use of the appliance in a safe way and understand the hazards involved.
Children shall not play with the appliance.
Cleaning and user maintenance shall not be made by children without supervision.

4 Scope of supply

- 1 x control device GEWAS 191 N, GEWAS 191 AN or GEWAS 191 ANOV
- 1 x water sensor GWF-1S
- 1 x solenoid valve according the device variant



GEWAS control unit



water sensor

at GEWAS 191 N / AN



plastic solenoid valve with integrated sieve sealing for hand assembly

at GEWAS 191 ...-M-H



Brass solenoid valve for hand assembly (incl. sealing)

at GEWAS 191 ...-M-...



Brass solenoid valve for pipe mounting

5 Installation and commissioning

5.1 Installation of the solenoid valve (for design type for hand assembly)

- Lock water feed lines.
- Insert sieve sealing ring.
Please take care having clean sealing surfaces.
- Connect solenoid with sleeve nut to the water feed by means of a right-hand turn.
- Check leak tightness by turning on the water supply.
→ In case of leakage repeat the process above.
- Screw water connection tube onto the outlet of the solenoid valve (use sealing ring or make sure that the tube itself is properly sealed!).

If the installation has been carried out correctly the sleeve nut can be tightened by hand. In case of leakage check if sealing has been inserted and if all sealing surfaces are clean; also check if the installation has been carried out correctly. If necessary repeat installation process.

Hint for commissioning: The solenoid will not be opened unless it has been connected to the activated control device.

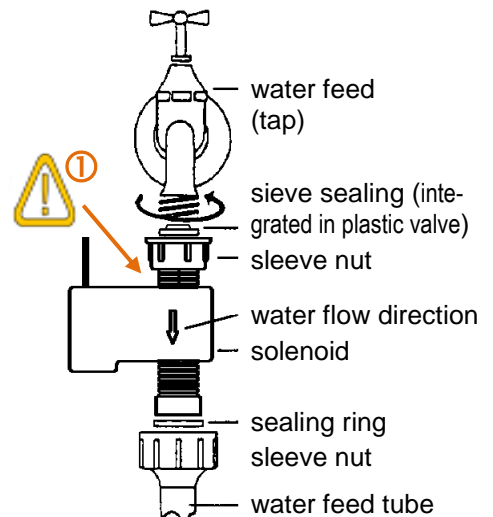

**Please ensure that the connection to the water feed are completely tight !!
A water leakage on this position can't be stopped by the solenoid!**



Do not apply turning force at housing, while mounted at tap - upper valve connection could be unscrewed and therefore getting untight !

5.2 Installation of the solenoid valve (for design types for pipe mounting)

- Lock water feed lines.
- Install solenoid valve in water line according to local regulations.
- Check leak tightness by turning on the water supply.

Hinweis für die Inbetriebnahme: Das Magnetventil wird nur dann geöffnet, wenn das Steuergerät eingeschaltet ist.



**Please ensure that the connection to the water feed are completely tight !!
A water leakage on this position can't be stopped by the solenoid!**



**The installation must be carried out by a specialist.
All typical safety precautions, sealing measures, etc. must be carried out correctly.**

5.3 Installation of the control unit and the water sensor

Note: The description refers to the GEWAS 191 AN

The GEWAS 191 ANOV do not have a solenoid valve connection - corresponding points in the description are therefore invalid.

- Make a rule to read the operating and maintenance advices before starting up the device.
- Place water sensor at desired position and fix it, if necessary.
Note: Choose best position for the water sensor, that both metal electrodes come into contact with water as early and reliable as possible! (Keep an eye on floor unevenness). Protect against unintended shifting, e.g. by using a screw or mounting tape.
- Please take care that the sensor electrodes do not touch any metallic surfaces, this may cause errors.
- Connect water sensor to the control unit.
- Open water feed line unless you have already done so.
- Plug in control device into a socket outlet with earthing contact.
=> Device is now active, the solenoid is open.
- Check water connection tubes for leakage.
- Connect device which is to be switched off in case of alarm to the socket outlet with earthing contact of the control device.
 (Note: With the GEWAS 191 N, there is no switch-off - The Schuko socket on the control unit is always active)

! Well done, your GEWAS device is now ready for use !

6 Function

If the water film at the water sensor exceeds 0.5 mm the control device automatically triggers an audible alarm and switches off the solenoid (GEWAS 191 N / AN).

The GEWAS 191 AN and GEWAS 191 ANOV also switches off the device connected to the control device.

To remove the alarm disconnect control device for a short time.

Note: The alarm will also be activated if the water sensor has been disconnected.

7 Alarm und operating signals

audible alarm at 1s interval:	alarm condition
audible alarm, short signal every 10s:	solenoid is not connected or defective
solenoid continuously switches on and of	insufficient power supply
audible alarm at 2.5s interval	insufficient power supply.

8 What to do in case of alarm

- The control device can only be switched off by disconnecting it.
- Seek and eliminate error causes.
- Possible error causes:
 - A water film is located at the water sensor.
 - The contacts of the water sensor are bypassed (e.g. via a metal surface)
 - The water sensor has been disconnected or is defective.
- Reconnect the control device.

9 Operating and maintenance advices

- 1 For reliable operation of the GEWAS the monitored liquid has to have a minimum conductivity of at least 50 $\mu\text{S}/\text{cm}$. Liquids with lower conductivity (e.g. deionised/demineralised water) a reliable detection is not possible.
- 2 The solenoid is servo-controlled; i.e. the pressure at the infeed side of the solenoid needs to exceed the outlet side pressure by at least 50 kPa / 0.5 bar (for the plastic valve) or. 15 kPa / 0.15 bar (for the brass valve)
This condition is fulfilled if the water feed line is open and the water can flow freely at the solenoid outlet. Unless this condition has been fulfilled the solenoid cannot open. In such a case remedy fault cause (e.g. activate water infeed of the device connected), disconnect control device and reconnect again.
- 3 When dead the solenoid will always be closed. In order to guarantee the required sealing properties, you have to make sure that there are no foreign objects (stones, sand etc.) in the solenoid line. We, therefore, recommend to clean the sieve insert of the solenoid regularly.
- 4 To prevent the solenoid valve from becoming inoperable due to limescale deposits, the GEWAS 191 N / AN switches the solenoid valve off and on briefly every approx. 24 hours during normal monitoring operation.
This is done for the first time approx. 12 hours after the GEWAS 191 N / AN has been put into operation.
- 5 In order to ensure long-time and trouble-free operation of the device, the functioning of the device has to be checked at regular intervals (as is the case with any safety device). To do so produce an alarm at least once a month by short-circuiting both water sensor contacts by means of a metal object (e.g. spoon, knife, etc.). Disconnect device and reconnect the device. The solenoid has to react with a clearly audible "clack" sound.
- 6 The control devices GEWAS 191 N and GEWAS 191 AN should not operate without solenoid connected!
If the function of the solenoid is not required the solenoid must still be connected to the control device. The connection of the solenoid to the water feed is not essential then.
- 7 The device has to be treated and handled carefully in accordance with the above specifications (do not throw, bump against, etc.). Protect from soiling.

8



!!! Do NOT use the GEWAS in a humid environment !!!

10 Decommissioning, reshipment and disposal

10.1 Decommissioning

Always disconnect the device before from its supply before decommission (e.g. at fuse). Valid general safety requirements shall be observed.

Please also make sure that connected Loads are disconnected also and are in a safe state.

10.2 Reshipment and disposal



All devices returned to the manufacturer have to be free of any residual of measuring media and other hazardous substances.

Measuring residuals at housing or sensor may be a risk for persons or environment



Use an adequate transport package for reshipment, especially for fully functional devices. Please make sure that the device is protected in the package by enough packing materials. Add the completed reshipment form of the GHM website.



The device must not be disposed in the unsorted municipal waste! Send the device directly to us (sufficiently stamped), considering the above if it should be disposed.

We will dispose the device appropriate and environmentally sound.

11 Specification

- Power supply:** 220 - 240V, 50/60Hz (control unit)
- Power consumption:** approx. 3 W
- Sensor input:** Connection (jack socket 2.5 mm, mono) for water sensor with max. 10 m cable length
- Solenoid valve connection:** Jack socket 3.5 mm, mono for solenoid valves of the GMV 191 ... series
- Control output:** by socket outlet in device housing (only for GEWAS 191 AN and GEWAS 191 ANOV)
(at GEWAS 191N the outlet is direct connected to the plug)
- Switching voltage:** equivalent to supply voltage
- Switching current:** max. 16A (ohmic load)
- Solenoid valve:** max. working pressure: 600 kPa (6 bar) servo controlled
pressure difference infeed/outfeed >50 kPa (0,5 bar)
- Working conditions:** 0 ... 50 °C, 0 ... 90 %RH (non condensing)
- Weight:**
 - control unit: approx. 290 g (GEWAS 191 AN)
approx. 275 g (GEWAS 191 N)
 - water sensor: approx. 43 g (at cable length = 2m)
 - solenoid valve: see below
- Dimensions:**
 - control unit: 110 x 65 x 45 mm (L x W x H)

Solenoid valve:	GMV 191	GMV 191-M-H	GMV 191-M-1/2	GMV 191-M-3/4	GMV 191-M-1
Mounting type	direct screw connection to 3/4" (e.g. water tap)		Pipe mounting with 1/2" internal thread	Pipe mounting with 3/4" internal thread	Pipe mounting with 1" internal thread
Material	Polyamide (glas fiber reinforced)	Brass	Brass		
Max. working pressure	600 kPa (6 bar) servo-controlled	1300 kPa (13 bar) servo-controlled		1000 kPa (10 bar) servo-controlled	
Pressure difference Inlet / outlet	> 50 kPa (0,5 bar)	> 15 kPa (0,15 bar)			
Max. flow rate	~ 40 l/min.		~ 90 l/min.	~ 170 l/min.
Control unit connection	~ 1.5 m cable, permanently connected to valve	approx. 1.5 m cable, connected via valve plug			
Weight	approx. 185 g	approx. 520 g	approx. 425 g	approx. 690 g	approx. 1090 g

Dimensions:
solenoid valve GMV 191:

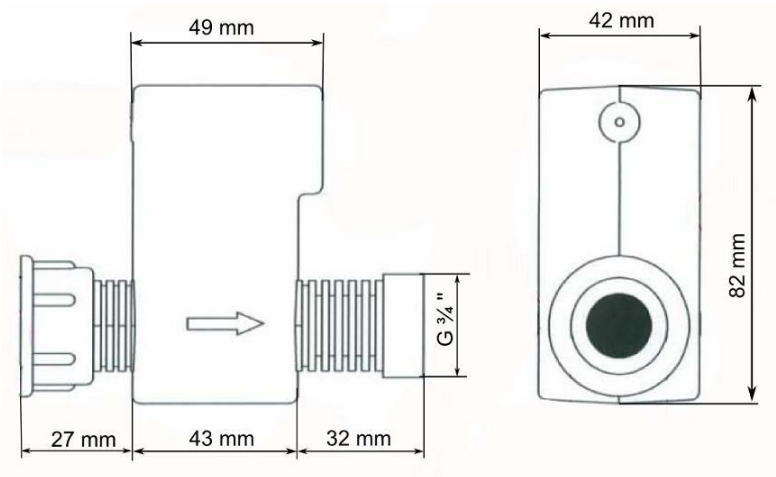

solenoid valve GMV 191-M-

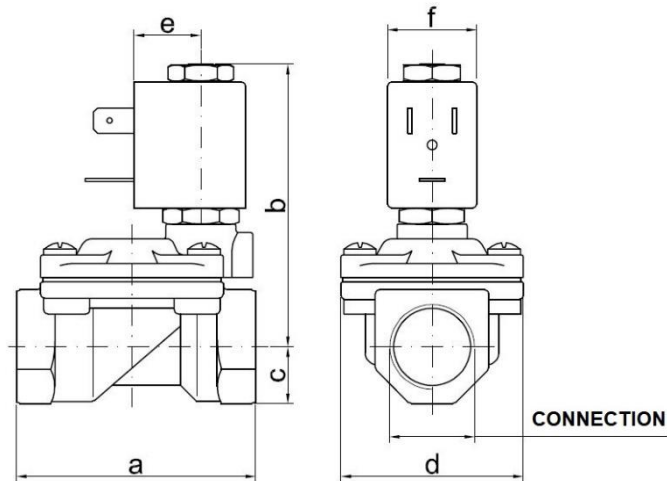

dimension in mm

Type	connection	a	b	c	d	e	f
..-M-1/2"	G 1/2" (DN12)	59	70	14	45	16	22
..-M-3/4"	G 3/4" (DN18)	79	76	18	55	16	22
..-M-1"	G 1" (DN25)	96	85	20	72	16	22

Directives and standards:

The instruments confirm to following European Directives:

- 2014/30/EU - EMC Directive
- 2014/35 EU - Low Voltage directive
- 2011/65/EU - RoHS

Applied harmonized standards:

- EN 61326-1 : 2013 emissions level: class B
emi immunity according to table 2
Additional fault: <1 %
- EN 60335-1 : 2012 protection IP20
pollution degree 2

Other approvals:

The solenoid valves are in accordance with the Regulation (EU) 1183/2012 and 1935/2004. The solenoid valves are according to the requirements of the KTW recommendation, the KTW-Leitlinie of the German Umweltbundesamt (Bgesundhbl. 2005) and the DVGW-worksheet W270.