

## Operating Manual for Digital Quick-Response Thermometer

### GMH 1170



WEEE-Reg.-Nr. DE93889386

**GHM Messtechnik GmbH • Standort Greisinger**

Hans-Sachs-Str. 26 • D-93128 Regenstauf

☎ +49 (0) 9402 / 9383-0 📠 +49 (0) 9402 / 9383-33 ✉ [info@greisinger.de](mailto:info@greisinger.de)

# CONTENTS

<b>1</b>	<b>GENERAL NOTE</b> .....	<b>2</b>
<b>2</b>	<b>SAFETY</b> .....	<b>2</b>
2.1	INTENDED USE .....	2
2.2	SAFETY SIGNS AND SYMBOLS .....	3
2.3	SAFETY GUIDELINES .....	3
<b>3</b>	<b>PRODUCT SPECIFICATION</b> .....	<b>3</b>
3.1	SCOPE OF SUPPLY.....	3
3.2	OPERATION AND MAINTENANCE ADVICE .....	3
<b>4</b>	<b>NOTES TO FUNCTIONS OF DEVICE</b> .....	<b>4</b>
4.1	IN GENERAL: MEASURING TEMPERATURE WITH THERMOCOUPLES .....	4
4.2	MIN-/MAX VALUE MEMORY .....	4
4.3	HOLD – FUNCTION.....	4
4.4	OFFSET AND SCALE ADJUSTMENT .....	4
<b>5</b>	<b>CONFIGURATION OF THE INSTRUMENT:</b> .....	<b>5</b>
5.1	AUTO POWER OFF TIME .....	5
5.2	DISPLAY UNIT: CHOICE OF THE TEMPERATURE DISPLAY UNIT °C OR °F.....	5
5.3	DISPLAY RESOLUTION: CHOICE OF THE TEMPERATURE DISPLAY RESOLUTION 1° OR 0.1° .....	5
<b>6</b>	<b>SYSTEM MESSAGES:</b> .....	<b>5</b>
<b>7</b>	<b>POP-UP CLIP</b> .....	<b>6</b>
<b>8</b>	<b>SPECIFICATION</b> .....	<b>7</b>
<b>9</b>	<b>RESHIPMENT AND DISPOSAL</b> .....	<b>7</b>
9.1	RESHIPMENT.....	7
9.2	DISPOSAL INSTRUCTIONS.....	7

## 1 General Note

Read this document carefully and get used to the operation of the device before you use it. Keep this document within easy reach near the device for consulting in case of doubt.

Mounting, start-up, operating, maintenance and removing from operation must be done by qualified, specially trained staff that have carefully read and understood this manual before starting any work.

The manufacturer will assume no liability or warranty in case of usage for other purpose than the intended one, ignoring this manual, operating by unqualified staff as well as unauthorized modifications to the device.

The manufacturer is not liable for any costs or damages incurred at the user or third parties because of the usage or application of this device, in particular in case of improper use of the device, misuse or malfunction of the connection or of the device.

The manufacturer is not liable for misprints.

## 2 Safety

### 2.1 Intended Use

The safety requirements (see below) have to be observed.

The device must be used only according to its intended purpose and under suitable conditions.

Use the device carefully and according to its technical data (do not throw it, strike it, ...)

Protect the device from dirt.

## 2.2 Safety signs and symbols

Warnings are labelled in this document with the followings signs:



**Caution!** This symbol warns of imminent danger, death, serious injuries and significant damage to property at non-observance.



**Attention!** This symbol warns of possible dangers or dangerous situations which can provoke damage to the device or environment at non-observance.



**Note!** This symbol point out processes which can indirectly influence operation or provoke unforeseen reactions at non-observance.

## 2.3 Safety guidelines

This device has been designed and tested in accordance with the safety regulations for electronic devices. However, its trouble-free operation and reliability cannot be guaranteed unless the standard safety measures and special safety advises given in this manual will be adhered to when using the device.

1. Trouble-free operation and reliability of the device can only be guaranteed if the device is not subjected to any other climatic conditions than those stated under "Specification".
2. If the device is transported from a cold to a warm environment condensation may cause in a failure of the function. In such a case make sure the device temperature has adjusted to the ambient temperature before trying a new start-up.



3. If there is a risk whatsoever involved in running it, the device has to be switched off immediately and to be marked accordingly to avoid re-starting. Operator safety may be a risk if:
  - there is visible damage to the device
  - the device is not working as specified
  - the device has been stored under unsuitable conditions for a longer time.
 In case of doubt, please return device to manufacturer for repair or maintenance.

4. **Warning:** Do not use this product as safety or emergency stop devices or in any other application where failure of the product could result in personal injury or material damage. Failure to comply with these instructions could result in death or serious injury and material damage.

Read this document carefully and get used to the operation of the device before you use it. Keep this document within easy reach near the device for consulting in case of doubt.

## 3 Product Specification

### 3.1 Scope of supply

The scope of supply includes:

- Device, incl. 9V battery block
- Operation Manual

### 3.2 Operation and maintenance advice

#### • Battery operation:

If 'bAt' is shown in the lower display the battery has been used up and needs to be replaced. However, the device will operate correctly for a certain time. If 'bAt' is shown in the upper display the voltage is too low to operate the device; the battery has been completely used up.



**The battery has to be taken out, when storing device above 50 °C.  
We recommend taking out battery if device is not used for a longer period of time.**

- Treat device carefully. Use only in accordance with above specification. (do not throw, hit against etc.). Protect plug and socket from soiling.
- Make sure that sensor and device are always subjected to the same temperature, i.e. try to avoid holding sensor plug in your hand for a longer period of time as well as subjecting device to an additional heat source as this may result in measuring inaccuracies.

# 4 Notes to Functions of Device

## 4.1 In General: Measuring Temperature With Thermocouples

- Temperature differences between the instrument and the probe connector may produce measuring errors. Therefore wait after connecting or touching the connector until the temperatures have adjusted. (can take up to 15 mins. )
- The device is suitable to measure large temperature ranges. But consider the allowable range of your probe!
- When measuring air temperature the probe has to be dry. Otherwise the cold due to the evaporation causes to low measuring.

## 4.2 MIN-/MAX Value Memory

watch MIN value (Lo):	press key 'Mode' shortly once	display changes between 'Lo' and MIN value
watch MAX value (Hi):	press key 'Mode' shortly once again	display changes between 'Hi' and MAX value
restore current value:	press key 'Mode' shortly once again	current value is displayed
clear MIN-/MAX- value:	press key 'Mode' for 2 seconds	MIN and MAX value are cleared. The display shows shortly 'CLr'.

## 4.3 Hold – Function

By shortly pressing the 'Hold' key the currently measured value is 'frozen',  
 The display changes between 'Hld' and the 'frozen' value  
 Pressing the key 'Hold' shortly once again resets the display to the current value.

*Please note: Measuring keeps on running in the background, the MIN/MAX values are updated continuously.*

## 4.4 Offset and Scale Adjustment

*The offset and scale adjustment is mainly intended to be used to compensate errors of the external temperature probes.*

*The display value is given by following formula:*

$$\begin{aligned} \text{unit} = \text{°C:} & \quad \text{Display} = (\text{measured value} - \text{offset}) * ( 1 + \text{scale adjustment} [\%] ) \\ \text{unit} = \text{°F:} & \quad \text{Display} = (\text{measured value} - 32\text{°F} - \text{offset}) * ( 1 + \text{scale adjustment} [\%] ) + 32\text{°F} \end{aligned}$$

**To adjust a measuring offset and scale proceed like follows:**

1. Switch off the instrument.
2. Press the 'Hold' key while switching on the instrument.  
Keep 'Hold' key pressed until 'OFS' appears in the display (about 3 seconds).
3. Press 'Mode' or 'Hold' key, the currently selected offset adjustment appears.
4. Choose the desired value by pressing 'Mode' or 'Hold' key. (max. input range: ±5.0°C or ±9.0°F)
5. Enter by pressing On/Off-key: SCL appears in the display
6. Press 'Mode' or 'Hold' key, the currently selected scale adjustment appears
7. Choose the desired value by pressing 'Mode' or 'Hold' key. (max. input range: ±5.00%)  
The input is displayed in %.

example: *scale adjustment is 4.00 => scale is increased by 4.00% => Scale = 104%  
 At a measured value of 100.0 (without offset correction) the instrument would show 104.0*

8. Store the values by pressing 'On/Off' key.



*Please note: If during the changing of the offset adjust no key is pressed within 20 seconds, the input will be aborted. Eventually made changes won't be stored!*

## 5 Configuration Of The Instrument:

To configure the instrument proceed like follows:

1. Switch off the instrument.
2. Press the 'Mode' key while switching on the instrument, keep 'Mode' key pressed until 'PoF' appears (about 3 seconds).

### 5.1 Auto Power Off Time

The auto power off time is entered in minutes. If no key is pressed during a measuring, the instrument switches itself off automatically after the entered period of time.

3. Press 'Mode' or 'Hold' key, the currently selected power off time will be displayed (off, 1..120min)
4. Enter the desired time by pressing 'Mode' or 'Hold' key.  
Possible input:   off:                   The auto power off function is deactivated (permanent operation)  
                  1...120:               auto power off time in minutes.
5. Confirm the value by pressing 'On/Off' key, 'Uni' appears in the display

### 5.2 Display Unit: Choice of the temperature display unit °C or °F

6. Press 'Mode' or 'Hold' key, the currently selected unit will be displayed (°C or °F)
7. Enter the desired unit by pressing 'Mode' or 'Hold' key.
8. Confirm the value by pressing 'On/Off' key, 'rES' appears in the display

### 5.3 Display Resolution: Choice of the temperature display resolution 1° or 0.1°

9. Press 'Mode' or 'Hold' key, the currently selected resolution will be displayed (1° or 0.1°)
10. Enter the desired resolution by pressing 'Mode' or 'Hold' key.  
0.1°: Display 0.1°C or 0.1°F. When exceeding the display range (>199.9°) the display automatically changes to 1° resolution  
1°: Display with 1°C or 1°F resolution
11. Confirm the value by pressing 'On/Off' key. The vales will be stored, the instrument will restart (segment test).



*Please note: If during the configuration no key is pressed within 20 seconds, the configuration will be aborted. Eventually made changes won't be stored!*

## 6 System Messages:

- Er. 1 = measuring range has been exceeded
- Er. 2 = meas. values have fallen below perm. range
- Er. 7 = System fault - the device has detected a system fault (defective or far outside allowable ambient temperature range)
- = No temperature probe connected or probe defective

If the symbol **"BAT"** is displayed at the left side of display, the battery is weak, measuring can be continued for a certain time. If **"bAt"** is displayed in the main display the battery is used up and needs to be replaced. Measuring is no more possible.

## 7 Pop-up clip

### Handling:

- Pull at label "open" in order to swing open the pop-up clip.
- Pull at label "open" again to swing open the pop-up clip further.

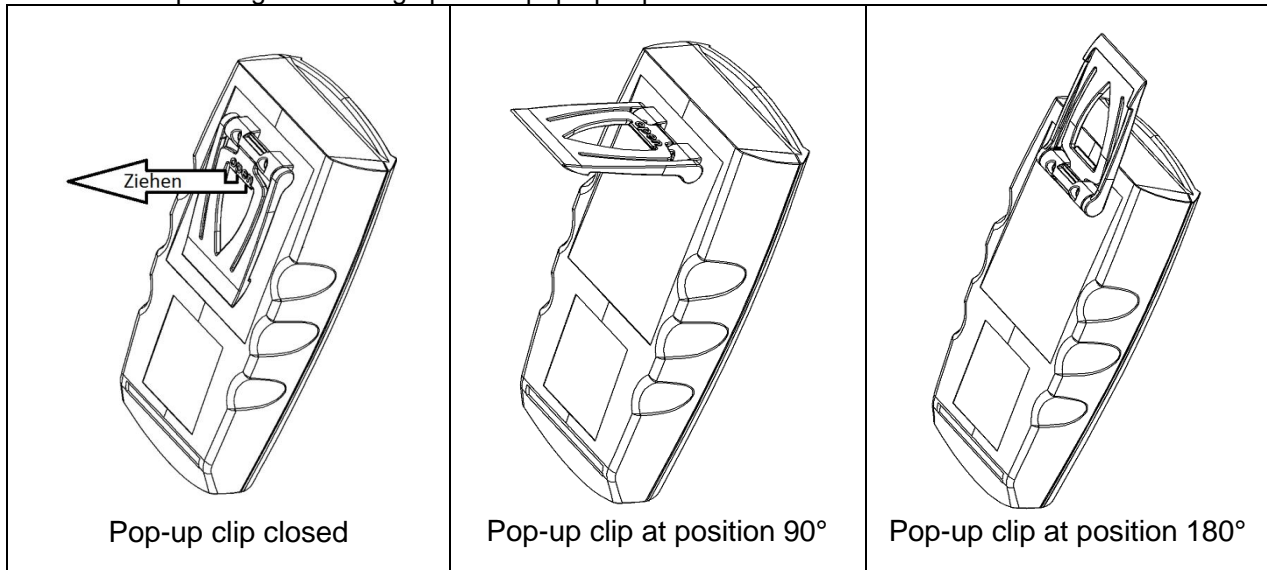

### Function:

- The device with a closed pop-up clip can be plainly laid onto a table or attached to a belt, etc.
- The device with pop-up clip at position 90° can be set up on a table, etc.
- The device with pop-up clip at position 180° can be suspended from a screw or the magnetic holder GMH 1300.

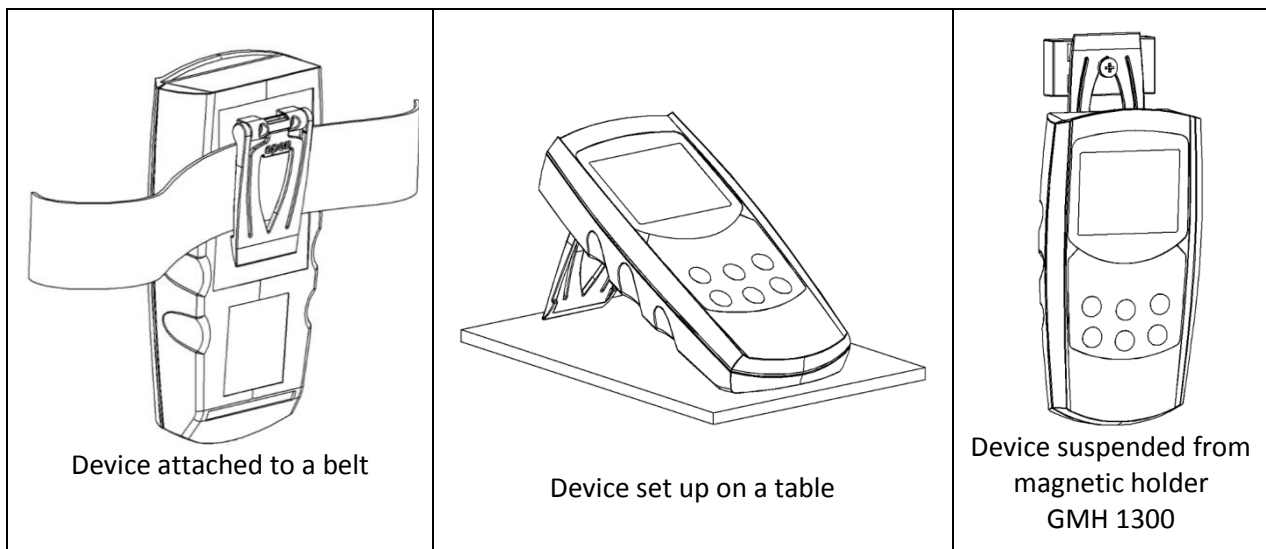



## 8 Specification

<b>Measuring range:</b>	-65,0 ..+199,9°C, resolution 0,1°C resp. -85,0 ... +199,9°F, resolution 0,1°F -65 .. +1150°C, resolution 1°C resp. -85 ... +1999°F, resolution 1°F
<b>Precision:</b> (±1 Digit) (at nominal temperature = 25°C)	-65,0°C ..+199,9°C: ±0,05% of meas. value ±0,2% full scale -65°C ... +1150°C: ±0,1% of meas. value ±0,2% full scale
<b>Temperature drift:</b>	0,01%/K
<b>Point of comparison:</b>	±0,3 °C
<b>Probe connection:</b>	standard flat-pin plug suitable for all NiCr-Ni (type K) probes
<b>Offset- and Scale:</b>	digital offset and scale adjustment via menu setting
<b>Measuring frequency:</b>	3 measurings per second
<b>Display:</b>	approx. 13 mm high, 3½-digit LCD
<b>Operation elements:</b>	3 keys for ON/OFF, min-/max-value display, hold
<b>Min-/Max-value memory:</b>	Min and max measured value is stored
<b>Hold key:</b>	the current measuring will be „frozen“
<b>Operating conditions:</b>	-25 to 50°C; 0 to 80 %RH (non-condensing)
<b>Storage temperature:</b>	-25 to 70°C
<b>Power supply:</b>	9V battery type JEC 6F22 (in scope of supply)
<b>Power consumption:</b>	approx. 150 µA
<b>Low battery warning:</b>	"BAT" automatically displayed if battery is low
<b>Auto off function:</b>	when the Auto Off Function is activated, the device switches automatically off, if keypad is not attended for a longer time (selectable 1..120min).
<b>Housing:</b>	impact resistant ABS-housing: approx.142 x 71 x 26 mm (HxWxD), integrated pop-up clip for table top or suspended use.
<b>Weight:</b>	approx. 150 g incl. battery
<b>EMC:</b>	The device corresponds to the essential protection ratings established in the Regulations of the Council for the Approximation of Legislation for the member countries regarding electromagnetic compatibility (2004/108/EG). Additional fault: <1%

## 9 Reshipment and Disposal

### 9.1 Reshipment



All devices returned to the manufacturer have to be free of any residual of measuring media and other hazardous substances. Measuring residuals at housing or sensor may be a risk for persons or environment



Use an adequate transport package for reshipment, especially for fully functional devices. Please make sure that the device is protected in the package by enough packing materials.

### 9.2 Disposal instructions



Batteries must not be disposed in the regular domestic waste but at the designated collecting points. The device must not be disposed in the unsorted municipal waste! Send the device directly to us (sufficiently stamped), if it should be disposed. We will dispose the device appropriate and environmentally sound.