



Manual for connection and operation of

GIA 2000 / GIR 2002 with option AAG...

as of version 1.3



GREISINGER electronic GmbH
D - 93128 Regenstauf, Hans-Sachs-Straße 26
Phone: 0049 9402 / 9383-0, Fax: 0049 9402 / 9383-33, e-mail: info@greisinger.de

INDEX

1. SAFETY REGULATIONS.....	3
2. INTRODUCTION.....	4
3. ELECTRIC CONNECTION	5
3.1. Terminal assignment.....	5
3.2. Connection data.....	5
3.3. Connecting an input signal.....	6
3.3.1. Connecting a Pt100 or Pt1000 RTD probe or a thermocouple probe.....	6
3.3.2. Connecting a 0(4)-20mA transmitter in 2-wire-technology	6
3.3.3. Connecting a 0(4)-20mA transmitter in 3-wire-technology	6
3.3.4. Connecting a 0-1V, 0-2V or 0-10V transmitter in 3-wire-technology.....	6
3.3.5. Connecting a 0-1/2/10V or 0-50mV transmitter in 4-wire-technology	7
3.3.6. Connecting a frequency- or rotation-signal.....	7
3.3.7. Connecting a counter signal.....	8
3.4. Connecting switching outputs (only for GIR 2002).....	9
3.5. Common wiring of several devices	9
4. CONFIGURATION OF THE MEASURING INPUT	10
4.1. Selecting an input signal type	10
4.2. Measuring voltage and current (0-50mV, 0-1V, 0-2V, 0-10V, 0-20mA, 4-20mA).....	11
4.3. Measuring temperature (Pt100, Pt1000 RTD probes and thermocouple type J, K, N, S or T).....	13
4.4. Measuring of frequency (TTL, switching-contact).....	14
4.5. Measuring of rotation speed (TTL, switching-contact).....	15
4.6. Up-/Downwards counter (TTL, switching-contact).....	16
4.7. Interface mode.....	18
5. CONFIGURATION OF THE ANALOG OUTPUT.....	19
5.1. Scaling the analog output.....	19
6. CONFIGURATION OF THE OUTPUT FUNCTIONS (ONLY FOR GIR 2002).....	20
6.1. Selection of the output function.....	20
6.2. 2-point-controller.....	21
6.3. Minimum/maximum-alarm.....	21
7. SWITCHING POINTS AND ALARM-BOUNDARIES (ONLY FOR GIR 2002).....	22
7.1. Menu calling.....	22
7.2. 2-point-controller.....	23
7.3. Minimum/maximum-alarm.....	23
8. OFFSET- AND SLOPE-ADJUSTMENT.....	24
8.1. Menu calling and adjustment	24
9. MIN-/MAX-VALUE MEMORY:.....	25
10. SERIAL INTERFACE:.....	25
11. ALARM DISPLAY (ONLY FOR GIR 2002).....	26
12. ERROR CODES	26
13. SPECIFICATION.....	28
14. DISPOSAL NOTES	29
15. SPECIAL FUNCTIONS (OPTIONALLY):.....	30
15.1. Tare function.....	30

1. Safety regulations

This device was designed and tested considering the safety regulations for electronic measuring devices.

Faultless operation and reliability in operation of the measuring device can only be assured if the General Safety Measures and the devices specific safety regulations mentioned in this users manual are considered.

1. Faultless operation and reliability in operation of the measuring device can only be assured if the device is used within the climatic conditions specified in the chapter "Specifications"
2. Always disconnect the device from its supply before opening it. Take care that nobody can touch any of the unit's contacts after installing the device.
3. Standard regulations for operation and safety for electrical, light and heavy current equipment have to be observed, with particular attention paid to the national safety regulations (e.g. VDE 0100).
4. When connecting the device to other devices (e.g. the PC) the interconnection has to be designed most thoroughly, as internal connections in third-party devices (e.g. connection of ground with protective earth) may lead to undesired voltage potentials.
5. The device must be switched off and must be marked against using again, in case of obvious malfunctions of the device which are e.g.:
 - visible damage.
 - no prescribed working of the device.
 - storing the device under inappropriate conditions for longer time.

When not sure, the device should be sent to the manufacturer for repairing or servicing.



ATTENTION: When running electric devices, parts of them will always be electrically live. Unless the warnings are observed serious personal injuries or damage to property may result. Skilled personnel only should be allowed to work with this device. For trouble-free and safe operation of the device please ensure professional transport, storage, installation and connection as well as proper operation and maintenance.

SKILLED PERSONNEL

Are persons familiar with installation, connection, commissioning and operation of the product and have professional qualification relating to their job.

For example:

- Training and instruction or qualifications to switch on or off, isolate, ground and mark electric circuits and devices or systems.
- Training or instruction according to the state.
- First-aid training.



ATTENTION:

Do NOT use this product as safety or emergency stopping device, or in any other application where failure of the product could result in personal injury or material damage.

Failure to comply with these instructions could result in death or serious injury and material damage.

2. Introduction

The GIA 2000 is a microprocessor controlled displaying device.
The GIR 2002 is a microprocessor controlled displaying, monitoring and controlling device.

The devices supports one universal interface for the connection of:

- Standard transmitter signals (0-20mA, 4-20mA, 0-50mV, 0-1V, 0-2V and 0-10V),
- RTD (for Pt100 and Pt1000),
- Thermocouple probes (type K, J, N, T and S),
- Frequency (TTL and switching contact).

As well as rotation measuring, counting, etc. ...

The GIR 2002 features additional one switching output, which can be configured as 2-point-controller or min./max. alarm.

The state of the switching outputs (relays) is displayed with the LED "1".

An upcoming alarm condition is displayed by LEDs "alarm", "max" and "min".

The devices are equipped with a scaleable analog output (0-10V, 0-20mA or 4-20mA).

Furthermore both devices supports one **EASY** bus-interface for communicating with a host computer that makes the device to a full functions **EASY** bus-module.

When leaving our factory the GIA 2000 and GIR 2002 has been subjected to various inspection tests and is completely calibrated.

Before the GIA 2000 or GIR 2002 can be used, it has to be configured for the customer's application.

Important: At the configuration of the device You have to adjust the input signal (see chapter 4) first and then the analog output function (see chapter 5), the output function (see chapter 6) or the offset-/slope- adjustment (see chapter 8)

Hint: *In order to avoid undefined input states and unwanted or wrong switching processes, we suggest to connect the device's switching outputs after You have configured the device properly.*

Hint: *By calling a configuration menu (configuration of the measuring input, configuration of the analog output, configuration of the output function, offset- and slope-adjustment) the measurement and regulation of the device will be deactivated.*

By leaving the menu the device will be reinitialised and the measuring/regulation will be started again.

At the input function "counter" the counter state will be reset by leaving the menu.

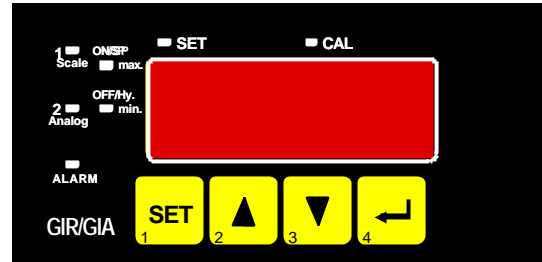

3. Electric Connection

Wiring and commissioning of the device must be carried out by skilled personnel only.

In case of wrong wiring the device may be destroyed. We can not assume any warranty in case of wrong wiring of the device.

3.1. Terminal assignment

15	EASY _{BUS} -Interface
14	EASY _{BUS} -Interface
13	Input: 0-10V
12	Input: 0-1V, 0-2V, mA, frequency, Pt100, Pt1000
11	Input: 0-50mV, thermocouples, Pt100
10	Input: GND, Pt100, Pt1000
9	Transmitter supply voltage -
8	Transmitter supply voltage +
7	Relay 1, break contact, * ¹ * ²
6	Relay 1, make contact, * ¹ * ²
5	Relay 1, input, * ¹ * ²
4	Analog output +
3	Analog output -
2	Supply voltage 230V _{AC} , * ¹
1	Supply voltage 230V _{AC} , * ¹

*¹ = or the corresponding designation on the label on the housing

*² = not available at GIA 2000

Pushbutton 5

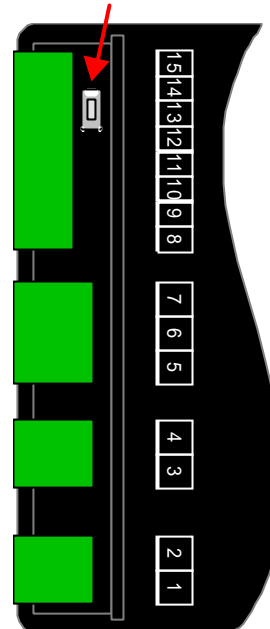

3.2. Connection data

	between terminals	typical		limitations		notes
		min.	max.	min.	max.	
Supply voltage	1 and 2	207 V _{AC}	244 V _{AC}	0 V _{AC}	253 V _{AC}	or corresponding designation on the type plate
Analog output	0-20mA	3 and 4		0 Ω	400 Ω	active signal not allowed
	4-20mA					
	0-10V					
Relay 1 (change-over contact) * ²	5, 6 and 7				253 V _{AC} 10A ohmic load	or corresponding designation on the type plate
Transmitter supply voltage	8 and 9	0 mA	20mA	0 mA	25 mA	
Input 0-50mV, TC, ...	11 and 10	0 V	3.3 V	-1 V	10 V, I<10mA	
Input mA	12 and 10	0 mA	20 mA	0 mA	30 mA	
Input 0-1(2)V, Freq, ...		0 V	3.3 V	-1 V	30 V, I<6mA	
Input 0-10V	13 and 10	0 V	10 V	-1 V	20 V	
Input Pt100 (Pt1000)	10 - 12			0 Ω	8 Ω	active signal not allowed
EASY _{BUS} -interface	14 and 15	12 V	36 V	0 V	42 V	

*² = not available at GIA 2000

These limits must not be exceeded (not even for a short time) !

3.3. Connecting an input signal

Please take care not to exceed the limitations of the inputs when connecting the device as this may lead to destruction of the device:

3.3.1. Connecting a Pt100 or Pt1000 RTD probe or a thermocouple probe

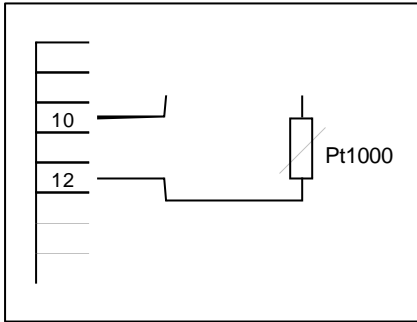

Pt1000-RTD probe (2-wire)

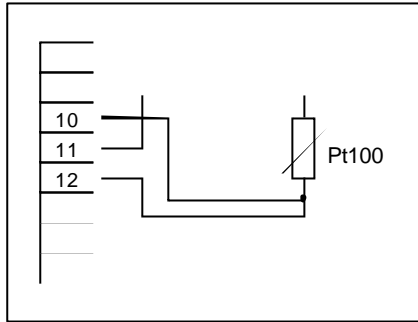

Pt100-RTD probe (3-wire)

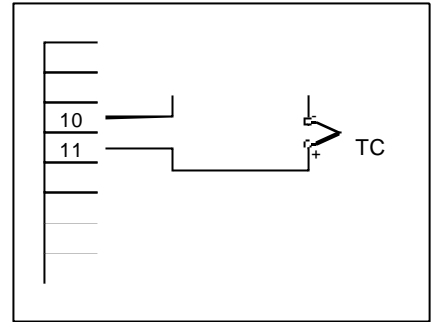

Thermocouple probe

3.3.2. Connecting a 0(4)-20mA transmitter in 2-wire-technology

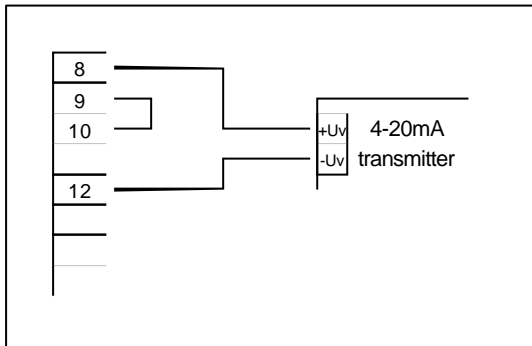

with in device integrated transmitter supply

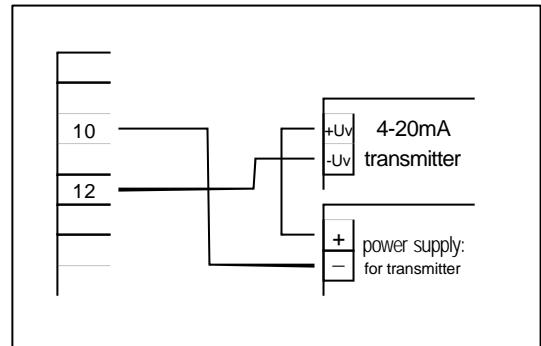

with separate transmitter supply

3.3.3. Connecting a 0(4)-20mA transmitter in 3-wire-technology

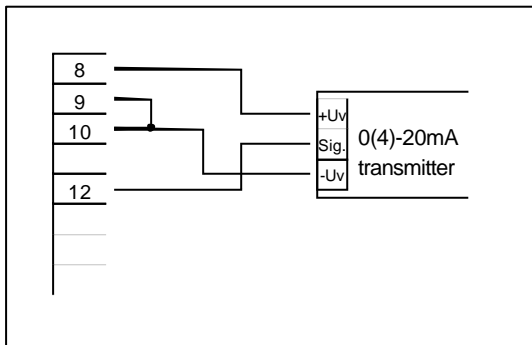

with in device integrated transmitter supply

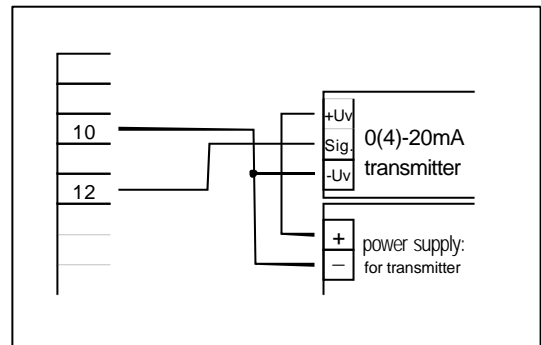

with separate transmitter supply

3.3.4. Connecting a 0-1V, 0-2V or 0-10V transmitter in 3-wire-technology

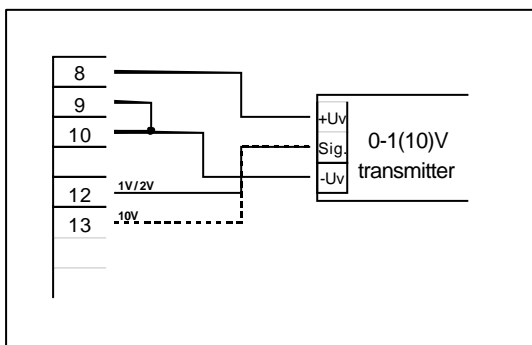

with in device integrated transmitter supply

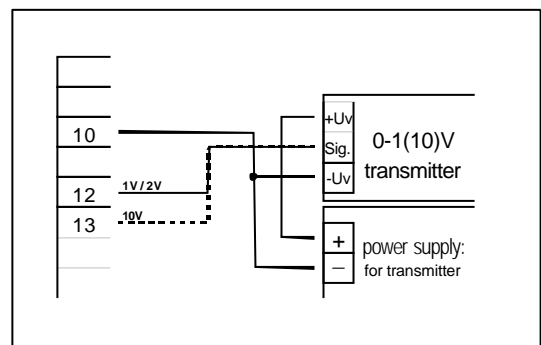

with separate transmitter supply

3.3.5. Connecting a 0-1/2/10V or 0-50mV transmitter in 4-wire-technology

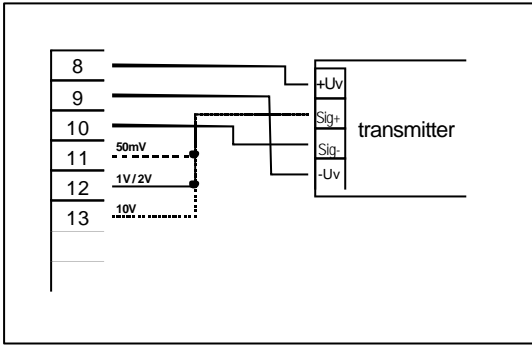

with in device integrated transmitter supply

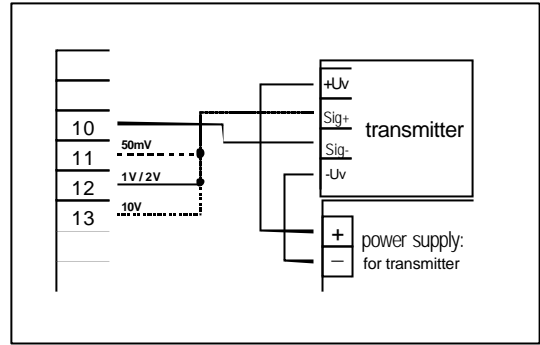

with separate transmitter supply

3.3.6. Connecting a frequency- or rotation-signal

When measuring frequency or rotation three different input signals can be selected in the device's configuration. There is the possibility of connecting an active signal (= TTL, ...), a passive sensor-signal with NPN (= NPN-output, push-button, relay, ...) or PNP (= a PNP output switching to +U_b, high-side push-button, ...).

When configuring the device with a NPN switching output, a pull-up-resistor (~11k referring to +3.3V) is connected internally. So when You use a device with NPN output You don't need to connect a resistor externally.

When configuring the device with a PNP switching output, a pull-down resistor (~11k referring to GND) is connected internally. So when You use a device with PNP output You don't need a resistor externally.

It may be that your measuring-signal source needs the connection of an external resistor e.g. the pull-up-voltage of 3.3V is not enough for the signal source, or you want to measure in the top level frequency range. In this case the input signal has to be treated like an active signal and you have to configure the device as „TTL“.

Hint: when connecting the device You have to take care not to exceed the limits of the input voltage respective the input current of the frequency-input.

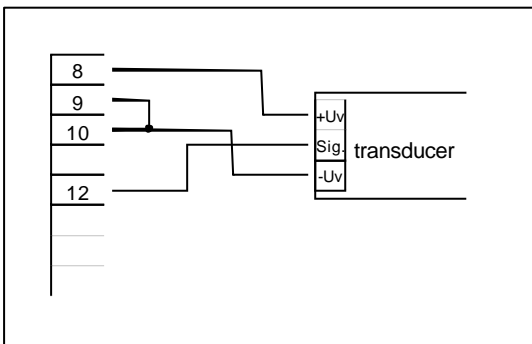

Connection of a transducer (with integrated supply) with TLL, NPN or PNP output

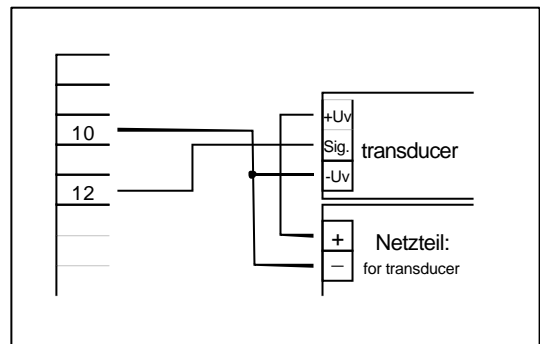

Connection of a transducer (with separate supply) with TLL, NPN or PNP output

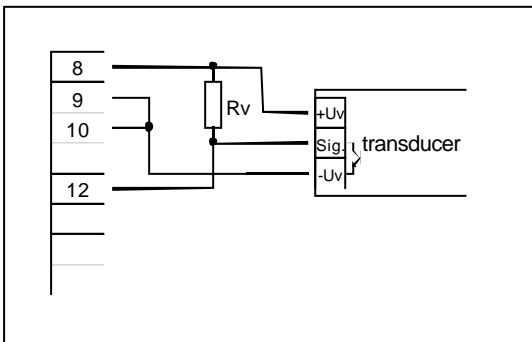

Connection of a transducer (with integrated supply) with NPN output and necessary external resistor

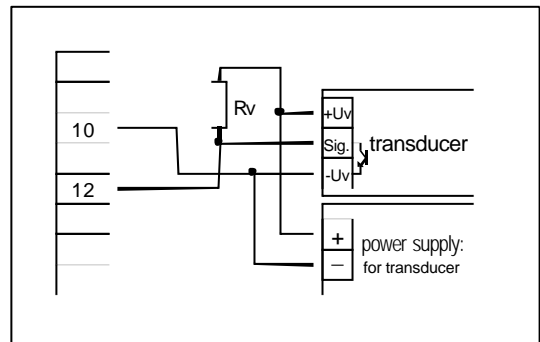

Connection of a transducer (with separate supply) with NPN output and necessary external resistor

Hint: R_v = 3k (with power supply voltage = 12V) or 7k (with power supply voltage = 24V), device configuration: Sens = TTL

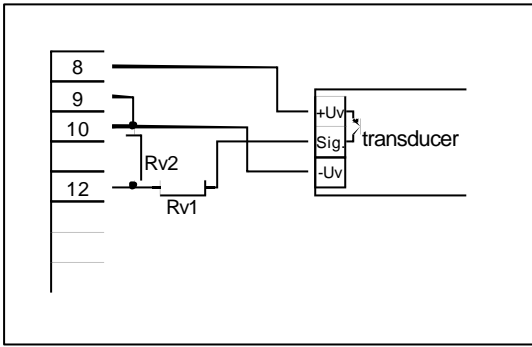

Connecting of a transducer (with integrated supply)
PNP output with external resistor wiring.

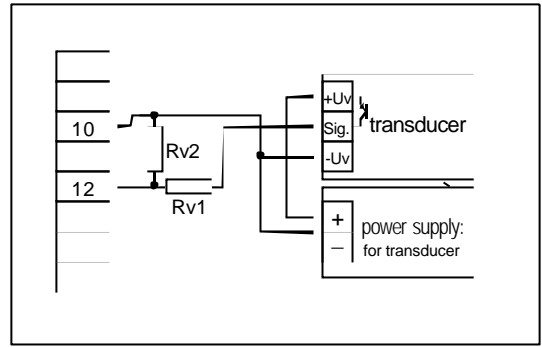

Connecting of a transducer (with separate supply)
PNP output and external resistor wiring.

Hint: Rv2 = 600 Ω, Rv1 = 1.8k Ω (with power supply voltage = 12V) or 4.2k Ω (with power supply voltage = 24V), device config.: Sens = TTL
(Rv1 is a current limiting resistor and may be shorted if necessary. It should never exceed the mentioned value.)

3.3.7. Connecting a counter signal

When configuring the device you can select 3 different input signal modes similar to the connection of frequency- and rotation-signals.

The connection of a sensor-signal for a counter-signal is the same used for the frequency- and rotation-signal. Please use the wiring diagram given in chapter 3.3.6.

There is the possibility to reset the counter. When connecting contact 11 with GND (contact 10) the counter will be reset. You can do this manually (e.g. with the help of a push-button) or automatically (with one switching output of the device – if available).

Hint: When connecting the device, take care not to exceed the limits of the input-voltage or the input-current of the frequency input.

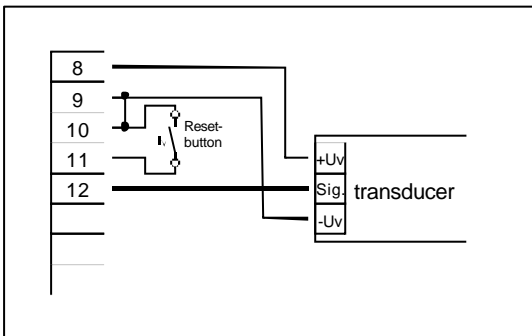

manually reset the device with the help of a push-button

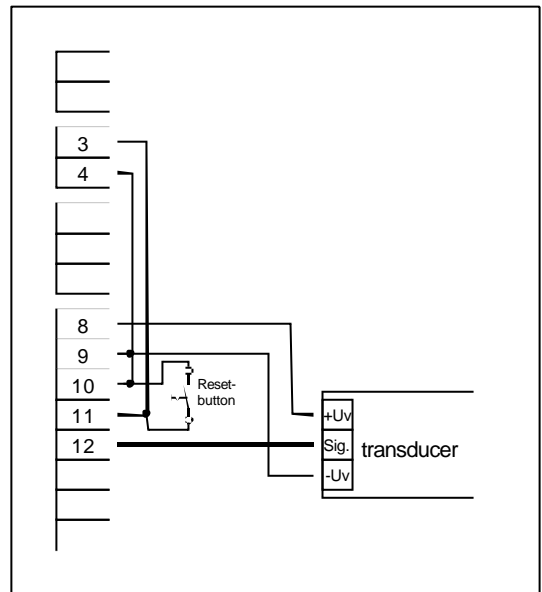

automatically resetting with the help of output 2 and additional resetting the device via push-button

3.4. Connecting switching outputs (only for GIR 2002)

Hint: *In order to avoid unwanted or wrong switching processes, we suggest to connect the device's switching outputs after you have configured the device's switching outputs properly.*

The device features two switching outputs (relays) by default.

Please take care that you must not exceed the limits of the voltage and of the maximum current of the switching outputs (not even for a short period of time). Please take extreme care when switching inductive loads (like coils or relays, etc.). Because of their high voltage peaks, protective measures (e.g. RC-element) to limit these peaks have to be taken.

Note: In case of configuring one output as an alarm output, the output will be active in idle state (no alarm present). The output relay opens when an alarm condition occurred.

3.5. Common wiring of several devices

At the standard devices the power supply, measuring input, transmitter supply and the serial interface are electrically isolated of each other.

At device options (e.g. dc-supply) it can occur that this isolation is not completely guaranteed (e.g. connection of – power supply to GND).

When interconnecting several of this devices you have to make sure that there is no potential displacement.

4. Configuration of the measuring input

General description and notes to the operating of the menu

By means of **button 1** you can go to the next parameter.

Additionally a given changing in the parameter setting can be confirmed by this button and the new value will be saved. Afterwards it will be changed to the parameter view again.

By means of **button 2 and 3** you can go from the parameter view to the parameter setting and adjust its value there.

Hint: The buttons 2 and 3 are featured with a 'roll-function'. When pressing the button once the value will be raised (button 2) by one or lowered (button 3) by one. When holding the button pressed for longer than 1 sec. the value starts counting up or down, the counting speed will be raised after a short period of time.

The device also features a 'overflow-function', when reaching the upper limit of the range, the device switches to the lower limit, vice versa.

By means of **button 4** a given changing will be cancelled in the parameter setting. The changing will be discarded and the former parameter value will be preserved.

In the parameter view button 4 closes the menu.

Please note: If you don't press any button for more than 10 sec. in the parameter setting, the adjustment will be cancelled, the changing discarded and it will be changed to the parameter view. If you don't press any button for more than 60 sec. in the menu, the menu will be automatically closed.

4.1. Selecting an input signal type

- Turn the device on and wait until it completed its built-in segment test.
- At the same time press the pushbutton on the rear side (button 5) and button 2 for >2 seconds. The device displays "InP" ('INPUT').
- Use button 2 or button 3 to select the input signal (see table below).
- Validate the selection with button 1. The display will show "InP" again.

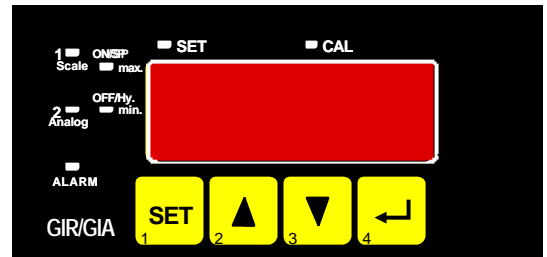

Depending on the selected input signal, additional configurations will be needed.

Input type	Signal	to select as input	proceed in chapter
Voltage signal	0 – 10 V	U	4.2
	0 – 2 V		
	0 – 1 V		
	0 – 50 mV		
Current signal	4 – 20 mA	I	4.2
	0 – 20 mA		
RTD	Pt100	t.rES	4.3
	Pt1000		
Thermocouples	NiCr-Ni (type K)	t.tc	4.3
	Pt10Rh-Pt (type S)		
	NiCrSi-NiSi (type N)		
	Fe-CuNi (type J)		
	Cu-CuNi (type T)		
Frequency	TTL-signal	FrEq	4.4
	Switch-contact NPN, PNP		
Rotation	TTL-signal	rPn	4.5
	Switch-contact NPN, PNP		

Counter up	TTL-signal	Co.uP	4.6
	Switch-contact NPN, PNP		
Counter up	TTL-signal	Co.dn	4.6
	Switch-contact NPN, PNP		
Interface mode	Serial interface	SEri	4.7

Please note: When changing the measuring mode “InP” all settings will be reset. Therefore you have to set all the other settings of the input configuration again. If there is a non-set parameter, the device will display “cccc” as a sign for a incomplete configuration after the menu is closed.

Note: When changing the measuring mode “InP” the values for the offset and slope-adjustment will be reset. Furthermore a change of the device scaling for standard signals (di.Lo, di.Hi) or of the resolution and unit for temperature can possibly influence the values of the offset and slope-adjustment. Therefore you may check your offset and slope-adjustment after changing the input configuration.

The change of the device scaling for standard signals (di.Lo, di.Hi) or of the resolution and unit for temperature can possibly change the switching and alarm points. Therefore you may check your output settings afterwards.

4.2. Measuring voltage and current (0-50mV, 0-1V, 0-2V, 0-10V, 0-20mA, 4-20mA)

This chapter describes how you configure the device for measuring voltage- or current-signals from an external transmitter. This instruction demands that you selected “U” or “I” as your desired input type like it is explained in chapter 4.1. The display has to show “InP”.

- Press button 1. The display shows “SEnS”.
- Select the desired input signal using button 2 or button 3.

Display	Input signal (voltage measuring)	Notes
10.00	0 – 10 V	
2.00	0 – 2 V	
1.00	0 – 1 V	
0.050	0 – 50 mV	

Display	Input signal (current measuring)	Notes
4-20	4 – 20 mA	
0-20	0 – 20 mA	

- Validate the selected input signal by pressing button 1. The display shows “SEnS” again.
- Press button 1 again, the display will show “dP” (decimal point).
- Select the desired decimal point place by pressing button 2 or button 3.
- Validate the selected decimal position by pressing button 1. The display shows “dP” again.
- Press button 1 again, the display will show “di.Lo” (Display Low = low display value).
- Use button 2 or button 3 to select the desired value the device should display when a 0mA, 4mA or 0V input signal is attached.
- Validate the selected value by pressing button 1. The display shows “di.Lo” again.
- Press button 1 again, the display will show “di.Hi” (Display High = high display value).
- Use button 2 or button 3 to select the desired value the device should display when a 20mA, 50mV, 1V, 2V or 10V input signal is attached.

- Validate the selected value by pressing button 1. The display shows “**di.Hi**” again.
- Press button 1 again. The display will show “**Li**” (Limit = Measuring range limit).
- Use button 2 or button 3 to select the desired measuring range limit..

Display	Measuring range limit	Notes
off	Deactivated	Exceeding of the measuring range limit is tolerable until the measuring limit (see note).
on.Er (on error)	Active, (displays error)	The measuring range limit is exactly bounded by the input signal. When exceeding or shortfailing the input signal the device will display an error message.
on.rG (on range)	Active, (displays the selected limit)	The measuring range limit is exactly bounded by the input signal. When exceeding or shortfailing the input signal the device will display the selected lower/upper display value. <i>[e.g. humidity: when shortfailing or exceeding, the device will display 0% or 100%]</i>

Note: When exceeding the measuring limit (~ upper measuring range + 10%) independently from the limit setting, the device will always display the corresponding error message (“Err.1”).
When shortfailing the measuring limit (~ lower measuring range - 10%) independently from the limit setting, the device will always display the corresponding error message (“Err.2”), if the input signal 4-20mA is chosen.
A shortfailing of 0V or 0mA is not detected.

- Press button 1 to validate the selection, the display shows “**Li**” again.
- When pressing button 1 again, the display will show “**FiLt**” (Filter = digital filter).
- Use button 2 or button 3 to select the desired filter [in sec.].
Selectable values: 0.01 ... 2.00 sec.

Explanation: this digital filter is a digital replica of a low pass filter.

Note: when using the input signal 0-50mV a filter value of at least 0.2 is recommended

- Press button 1 to validate your value, the display shows “**FiLt**” again.
- When pressing button 1 again, the display shows “**InP**” ('INPUT') again.

Now your device is adjusted to your input signal.

- Press now button 4 to exit the input configuration menu.

4.3. Measuring temperature (Pt100, Pt1000 RTD probes and thermocouple type J, K, N, S or T)

This chapter describes how to configure the device for temperature measuring with the help of external platinum RTD probes or thermocouple probes. This instruction demands that you selected **"t.res"** or **"t.tc"** as your desired input type like it is explained in chapter 4.1. The device has to display **"InP"**.

- When pressing button 1 the display shows **"SEnS"**.
- Use button 2 or button 3 to select your desired input signal.

Display	Input signal (RTD)	Notes
100	Pt100 (3-wire)	Meas.-range: -50.0 ... +200.0 °C (-58.0 ... + 392.0 °F)
		Meas.-range: -200 ... + 850 °C (-328 ... + 1562 °F)
1000	Pt1000 (2-wire)	Meas.-range: -200 ... + 850 °C (-328 ... + 1562 °F)

Display	Input signal (Thermocouples)	Notes
niCr	NiCr-Ni (Type K)	Meas.-range: -270 ... +1372 °C (-454 ... + 2502 °F)
		Meas.-range: -70.0 ... +250.0 °C (-94.0 ... + 482.0 °F)
S	Pt10Rh-Pt (Type S)	Meas.-range: -50 ... +1750 °C (- 58 ... + 3182 °F)
n	NiCrSi-NiSi (Type N)	Meas.-range: -270 ... +1350 °C (-454 ... + 2462 °F)
		Meas.-range: -100.0 ... +300.0 °C (-148.0 ... + 572.0 °F)
J	Fe-CuNi (Type J)	Meas.-range: -170 ... + 950 °C (-274 ... + 1742 °F)
		Meas.-range: -70.0 ... +300.0 °C (-94.0 ... + 572.0 °F)
t	Cu-CuNi (Type T)	Meas.-range: -270 ... + 400 °C (-454 ... + 752 °F)
		Meas.-range: -70.0 ... +200.0 °C (-94.0 ... + 392.0 °F)

- Validate the selected input signal by pressing button 1. The display shows **"SEnS"** again.
- Press button 1 to again, the display will show **"rES"** (resolution).
This menu item is not available at the input signal Pt1000 and Pt10Rh-Pt (type S).
- You can chose whether the temperature is displayed with **0.1°** or **1°** with button 2 or 3.
- Validate the selected resolution by pressing button 1. The display shows **"rES"** again.
- Press button 1 again, the display will show **"Unit"** (the unit you want to display).
- Use button 2 or button 3 to select whether you want to display **°C** or **°F**.
- Validate the selected unit by pressing button 1. The display shows **"Unit"** again.
- Press button 1 to again, the display will show **"FiLt"** (Filter = digital filter).
- Use button 2 or button 3 for setting the desired filter value [in sec.].
Selectable values: 0.01 ... 2.00 sec.
Explanation: this digital filter is a digital replica of a low pass filter.
- Press button 1 to validate your value, the display shows **"FiLt"** again.
- When pressing button 1 again, the display shows **"InP"** ('INPUT') again.

Now your device is adjusted to your input signal.

- Press now button 4 to exit the input configuration menu.

4.4. Measuring of frequency (TTL, switching-contact)

This chapter describes how to configure the device for measuring frequency.

This instruction demands that you selected "**FrEq**" as your desired input type like it is explained in chapter 4.1. The device has to display "**InP**".

- When pressing button 1 the display will show "**SEnS**".
- Use button 2 or button 3 to select the desired input signal.

Display	Input signal	Note
ttL	TTL-signal	
nPn	Switching contact, NPN	For direct connection of a passive switching contact (e.g. push button, relay) or Transmitter with NPN output. A pull-up-resistor is internally connected. <i>Hint: when using push-buttons or relays, they must be bounce-free!</i>
PnP	Switching contact, PNP	For direct connection of a transmitter with PNP output. A pull-down-resistor is internally connected.

*Hint: For the connection of a frequency-transmitter, please follow the instructions given in chapter 3.3.6
When connecting a switching-contact-transmitter with increased frequency range (= with external circuitry) you have to select TTL as your desired input signal.*

- Validate your selected input signal by pressing button 1. The display shows "**SEnS**" again.
- When pressing button 1 again, the display will show "**Fr.Lo**" (frequency low = lower frequency range limit).
- Use button 2 or button 3 to select the lowest frequency that may occur when measuring.
- Press button 1 to validate your selection. The display shows "**Fr.Lo**" again.
- When pressing button 1 again, the display will show "**Fr.Hi**" (frequency high = upper frequency range limit).
- Use button 2 or button 3 to select the highest frequency that may occur when measuring.
- Press button 1 to validate your selection. The display shows "**Fr.Hi**" again.
- When pressing button 1 again, the display will show "**dP**" (decimal point).
- Use button 2 or button 3 to select the desired decimal point position.
- Press button 1 to validate your selection. The display shows "**dP**" again.
- When pressing button 1 again, the display will show "**di.Lo**" (display low = display at lower frequency range limit).
- Set the value the device shall display at the lower frequency range limit by pressing button 2 or button 3.
- Press button 1 to validate your selection. The display shows "**di.Lo**" again.
- When pressing button 1 again, the display will show "**di.Hi**" (display high = display at upper frequency range limit).
- Set the value the device shall display at the upper frequency range limit by pressing button 2 or button 3.
- Press button 1 to validate your selection. The display shows "**di.Hi**" again.
- When pressing button 1 again, the display will show "**Li**" (limit = measuring range limitation).
- Use button 2 or button 3 to select the desired measuring range limitation.

Display	Measuring range limit	Note
off	Inactive	Exceeding of the measuring-frequency is tolerable until you reach the maximum measuring range limit.
on.Er	active, (error indicator)	The measuring range is exactly bounded by the selected frequency-measuring-range-limit. When exceeding or shortfaling of the limit the device will display an error message.

on.rG	active, (frequency range limit)	The measuring range is exactly bounded by the selected frequency-measuring-range-limit. When exceeding or shortfalling of the limit the device will display the lower or upper display-range-limit. <i>[e.g. humidity: when shortfalling or exceeding, the device will display 0% or 100%]</i>
--------------	---------------------------------	---

Hint: When exceeding the maximum range limit (10kHz) independently from the limit setting an error message will be displayed ("Err.1").

- Press button 1 to validate your selection. The display shows "**Li**" again.
- When pressing button 1 again, the display will show "**FiLt**" (Filter = digital filter).
- Use button 2 or button 3 to select the desired filter value [in sec.].
Usable values: 0.01 ... 2.00 sec.

Explanation: this digital filter is a digital replica of a low pass filter.

- Press button 1 to validate your selection. The display shows "**FiLt**" again.
- When pressing button 1 again, the display shows "**InP**" ('INPUT') again.

Now your device is adjusted to your input signal.

- Press now button 4 to exit the input configuration menu.

4.5. Measuring of rotation speed (TTL, switching-contact)

This chapter describes how to configure the device for measuring rotation speed.

This instruction demands that you selected "**rPn**" as your desired input type like it is explained in chapter 4.1. The device has to display "**InP**".

- When pressing button 1 the device will display "**SEnS**".
- Use button 2 or button 3 to select the desired input signal.

Display	Input-signal	Notes
ttL	TTL-signal	
nPn	Switching contact, NPN	For direct connection of a passive switching contact (e.g. push button, relay) or transmitter with NPN output. A pull-up-resistor is internally connected. <i>Hint: when using push-buttons or relays, they must be bounce-free!</i>
PnP	Switching contact, PNP	For direct connection of a transmitter with PNP output. A pull-down-resistor is internally connected.

*Hint: For the connection of a frequency-transmitter, please follow the instructions given in chapter 3.3.6
When connecting a switching-contact-transmitter with increased frequency range (= with external circuitry) you have to select TTL as your desired input signal.*

- Press button 1 to validate your selected input signal. The display shows "**SEnS**" again.
- When pressing button 1 again, the display will show "**diu**" (divisor).
- Use button 2 or 3 to select your desired divisor.
Set the divisor to the pulses per rotation the transmitter supplies.
- Press button 1 to validate your selection. The display shows "**diu**" again.
- When pressing button 1 again, the display will show "**dP**" (decimal point).
- Use button 2 or button 3 to select the desired decimal point position.

Use the decimal point position to change the resolution of your measurement. The more the decimal point position is on the left, the finer the resolution will become. Please note that you lower the maximum value that can be displayed, either.

Example: your engine runs with 50 rotations per minute.

With no decimal point the device will display something like 49 – 50 – 51, the maximum value that can be displayed is 9999 rotations per minute.

With the decimal point position on the left e.g. XX.XX the device will display something like 49.99 – 50.00 – 50.01, but the maximum value that can be displayed is 99.99 rotations per minute.

- Press button 1 to validate your selection. The display shows “**dP**” again.
- When pressing button 1 again, the display shows “**InP**” ('INPUT') again.

Now your device is adjusted to your input signal.

- Press now button 4 to exit the input configuration menu.

4.6. Up-/Downwards counter (TTL, switching-contact)

The upwards counter starts counting upwards from 0 according to its settings.

The downwards counter starts counting downwards from the upper value that had been selected.

The present value of the counter can be reset anytime by connecting pin 11 to GND (pin 10). The counter starts from its beginning as you disconnect pin 11 and pin 10.

Feature: The present counter value won't be lost if the voltage supply is disconnected. After restarting the counter starts from this value.

This chapter describes how to configure the device as a counter.

This instruction demands that you selected “**Co.up**” or “**Co.dn**” as your desired input type like it is explained in chapter 4.1. The device has to display “**InP**”.

- When pressing button 1 the display will show “**SEnS**”.
- Use button 2 or button 3 to select the desired input signal.

Display	Input-signal	Note
ttL	TTL-signal	
nPn	Switching contact, NPN	For direct connection of a passive switching contact (e.g. push button, relay) or transmitter with NPN output. A pull-up-resistor is internally connected. <i>Hint: when using push-buttons or relays, they must be bounce-free!</i>
PnP	Switching contact, PNP	For direct connection of a transmitter with PNP output. A pull-down-resistor is internally connected.

Hint: For connecting a frequency-transmitter, please follow the instructions given in chapter 3.3.7
When connecting a switching-contact-transmitter with increased frequency range (= with external circuit) you have to select TTL as your desired input signal.

- Press button 1 to validate your selected input signal. The display shows “**SenS**” again.
- When pressing button 1 again, the device will be displaying “**EdGE**” (signal edge).
- Use button 2 or button 3 to select the desired signal edge.

Display	Signal edge	Note
PoS	Positive	The counter is triggered on the positive (rising) edge.
nEG	Negative	The counter is triggered on the negative (falling) edge.

- Press button 1 to validate your selection, the display shows “**EdGE**” again.
- When pressing button 1 again, the display will show “**diu**” (divisor = pre-scaling factor).

- Use button 2 or button 3 to select the desired pre-scaling factor.

The incoming pulses will be divided with the selected pre-scaling factor, after that they will be transmitted to the device for further processing.

By this factor you can adapt the device to your transmitter or select a pre-scaling factor for large values

Example 1: Your flow rate transmitter supplies 165 pulses per litre. When setting a pre-scaling factor of 165 every 165th pulse (so 1 pulse per litre) will be used for further processing.

Example 2: Your transmitter is supplying about 5 000 000 pulses during the measurement, which exceeds the limit of the GIA20EB. But when setting a pre-scaling factor of 1000 only every 1000th pulse is used for further processing. So you only got a value 5000 which won't exceed the limit of the GIA20EB.

- Press button 1 to validate your selection. The display shows "**diu**" again.
- Press button 1 again. The display shows "**Co.Hi**" (counter high = upper counting range limit).
- Use button 2 or button 3 to select the maximum pulse-count (after pre-scaling factor) for the counting process.

*Example: Your flow rate transmitter is supplying 1800 pulses per litre, you selected a pre-scaling factor of 100 and you are expecting a maximum flow rate of 300 litres during the measurement. With a pre-scaling factor of 100 selected, you will get 18 pulses per litre. With a maximum flow rate of 300 litres you will be getting a pulse count of $18 * 300 = 5400$.*

- Press button 1 to validate your selection. The display shows "**Co.Hi**" again.
- When pressing button 1 again, the device will be displaying "**dP**" (decimal point).
- Use button 2 or button 3 to select the desired decimal point position.
- Press button 1 to validate your selected decimal point position. The display shows "**dP**" again.
- Press button 1 again. The display shows "**di.Hi**" (display high = upper display range limit).
- Use button 2 or button 3 to set the value to be displayed when the maximum pulse (setting of co.Hi) count is reached.

Example: Your flow rate transmitter is supplying 1800 pulses per litre and you are expecting a maximum flow rate of 300 litres. You selected a pre-scaling factor of 100 and a counter range limit of 5400. When wanting a resolution of 0.1 litres shown in the display of the device you would have to set the decimal point position to ---.- and a display range limit of 300.0.

- Press button 1 to validate your selection. The display shows "**di.Hi**" again.
- Press button 1. The display will show "**Li**" (Limit = measuring range limit).
- Use button 2 or button 3 to select the desired measuring range limitation.

Display	Measuring range limit	Note
off	Inactive	Exceeding of the counter range is tolerable until you reach the maximum measuring range limit.
on.Er	active, (error indicator)	The measuring range is exactly bounded by the selected counter-range-limit. When exceeding or shortfalling of the limit the device will display an error message.
on.rG	active, (measuring range limit)	The measuring range is exactly bounded by the selected counter-range-limit. When exceeding or shortfalling of the limit the device will display the upper counter-range-limit or 0

Hint: The lower counter-range-limit (for configured downwards counter) is fixed to 0.

- Press button 1 to validate your selection. The display shows "**Li**" again.
- When pressing button 1 again, the display shows "**InP**" ('INPUT') again.

Now your device is adjusted to your input signal.

- Press now button 4 to exit the input configuration menu.

4.7. Interface mode

When the device is in the interface mode it won't make any measurements by itself. The value shown in the device's display is sent via serial interface. But the switching and alarm functions of the displayed value are still available.

*The **EASY** bus-Address of the device needed for the communication can be set manually with the device itself or with the help of an **EASY** bus-software (like EbxKonfig). Please note, when carrying out an **EASY** bus-system-initialisation the device's address will be reset automatically.*

This chapter describes how to configure the device as an **EASY** bus-display.

This instruction demands that you selected "**Seri**" as your desired input type like it is explained in chapter 4.1. The device has to display "**InP**".

- When pressing button 1 again, the device will display "**Adr**" (address).
- Use button 2 or button 3 to select the desired address [0 ... 239] of the device.
- Press button 1 to validate the selected device address. The display shows "**Adr**" again.
- When pressing button 1 again, the device will be displaying "**dP**" (decimal point).
- Use button 2 or button 3 to select the desired decimal point position.
- Press button 1 to validate your selected decimal point position. The display shows "**dP**" again.
- When pressing button 1 again, the display shows "**InP**" ('INPUT') again.

You don't need any further configuration.

- Press now button 4 to exit the input configuration menu.

5. Configuration of the analog output

A change of the input configuration can possibly influence the configuration of the analog output. (e.g. changing of scaling for standard signals or changing of resolution or unit for temperature)
Therefore the analog output configuration should be done after the input configuration has been finished.

Additionally you may check your output settings after the input configuration has been changed.

General description and notes to the operating of the menu

By means of **button 1** you can go to the next parameter.

Additionally a given changing in the parameter setting can be confirmed by this button and the new value will be saved. Afterwards it will be changed to the parameter view again.

By means of **button 2** and **3** you can go from the parameter view to the parameter setting and adjust its value there.

Hint: The buttons 2 and 3 are featured with a 'roll-function'. When pressing the button once the value will be raised (button 2) by one or lowered (button 3) by one. When holding the button pressed for longer than 1 sec. the value starts counting up or down, the counting speed will be raised after a short period of time.

The device also features a 'overflow-function', when reaching the upper limit of the range, the device switches to the lower limit, vice versa.

By means of **button 4** a given changing will be cancelled in the parameter setting. The changing will be discarded and the former parameter value will be preserved.

In the parameter view button 4 closes the menu.

Please note: If you don't press any button for more than 10 sec. in the parameter setting, the adjustment will be cancelled, the changing discarded and it will be changed to the parameter view. If you don't press any button for more than 60 sec. in the menu, the menu will be automatically closed.

5.1. Scaling the analog output

The analog output can be scaled within the display range.

- Turn the device on and wait until it completed its built-in segment test.
- At the same time press the pushbutton on the rear side (button 5) and button 1 for >2 seconds.
The device displays "dA.Lo" (d/a converter low = low analog output value).
- Use button 2 or button 3 to select the desired display value corresponding to the analog output value 0mA, 4mA or 0V.
- Validate the selected value by pressing button 1. The display shows "dA.Lo" again.
- Press button 1 again, the display will show "dA.Hi" (d/a converter high = high analog output value).
- Use button 2 or button 3 to select the desired display value corresponding to the analog output value 20mA or 10V
- Validate the selected value by pressing button 1. The display shows "dA.Hi" again.
- Press button 1 again, the display will show "dA.Er" (d/a converter error = preferred state of analog output).
- Use button 2 or button 3 to set the preferred analog output state in case of an error.

Display	Preferred state of the output	Note
off	Inactive in case of an error	output signal = 0 mA or 0 V
on	Active in case of an error	output signal = >23 mA or >10.5 V

- Press button 1 to validate the selection. The display shows "dA.Er" again.
- When pressing button 1 again, the display shows "dA.Lo" again.

Now you have finished the analog output configuration.

- Press now button 4 to exit the analog output configuration menu.

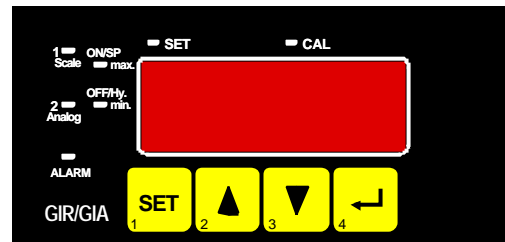

6. Configuration of the output functions (only for GIR 2002)

A change of the input configuration can possibly influence the switching points and alarm boundaries. (e.g. changing of scaling for standard signals or changing of resolution or unit for temperature)

Therefore the output configuration and switching points / alarm boundaries adjustment should be done after the input configuration has been finished.

Additionally you may check your output settings after the input configuration has been changed.

General description and notes to the operating of the menu

By means of **button 1** you can go to the next parameter.

Additionally a given changing in the parameter setting can be confirmed by this button and the new value will be saved. Afterwards it will be changed to the parameter view again.

By means of **button 2 and 3** you can go from the parameter view to the parameter setting and adjust its value there.

Hint: The buttons 2 and 3 are featured with a 'roll-function'. When pressing the button once the value will be raised (button 2) by one or lowered (button 3) by one. When holding the button pressed for longer than 1 sec. the value starts counting up or down, the counting speed will be raised after a short period of time.

The device also features a 'overflow-function', when reaching the upper limit of the range, the device switches to the lower limit, vice versa.

By means of **button 4** a given changing will be cancelled in the parameter setting. The changing will be discarded and the former parameter value will be preserved.

In the parameter view button 4 closes the menu.

Please note: If you don't press any button for more than 10 sec. in the parameter setting, the adjustment will be cancelled, the changing discarded and it will be changed to the parameter view. If you don't press any button for more than 60 sec. in the menu, the menu will be automatically closed.

6.1. Selection of the output function

- Turn the device on and wait until it completed its built-in segment test.
- At the same time press the pushbutton on the rear side (button 5) and button 1 for >2 seconds. The device displays "outP" ('output').
- Use button 2 or button 3 to select the output function. According your selection the outlets will be allocated as the following table shows:

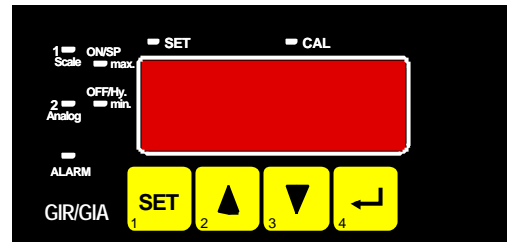

Description	To select as output	Output 1 (change-over contact)	See chapter
No output, device is used as display unit	no	off	--
2-point-controller	2P	Switching function 1	6.2
Min-/Max-alarm	AL.F1	Min-/Max-alarm, inverse	6.3

- Press button 1 to validate the selected output function. The display shows "outP" again.

Hint: The settings for the switching and alarm points can be made later in an extra menu (see chapter 7)

6.2. 2-point-controller

This chapter describes how to configure the device as a 2-point-controller and how to adjust the switching values. This instruction demands that you selected **"2P"** as your desired output function like it is explained in chapter 6.1.

- Press button 1. The device will be displaying **"1.on"** (turn-on-point of switching function 1).
- Use button 2 or button 3 to set the desired value, the device's switching function 1 should be turning on.
- Press button 1 to validate your selection. The display shows **"1.on"** again.
- Press button 1 again, the device will be displaying **"1.off"**. (turn-off-point of switching function 1)
- Use button 2 or button 3 to set the desired value, the device's switching function 1 should be turning off.
- Press button 1 to validate your selection. The display shows **"1.off"** again.
- Press button 1 again, the device will be displaying **"1.dEL"** (delay of switching function 1).
- Use button 2 or button 3 to set the desired value [*in sec*] for the switching-delay of switching function 1.
- Press button 1 to validate the selection. The display shows **"1.dEL"** again.
- When pressing button 1 again, the device will display **"1.Err"** (preferred state of switching function 1).
- Use button 2 or button 3 to set the desired initial state in case of an error.

Display	Preferred state of the output	Note
off	Inactive in case of an error	
on	Active in case of an error	

- Press button 1 to validate the selection. The display shows **"1.Err"** again.
- When pressing button 1 again, the display shows **"outP"** ('output') again.

Now you have finished the output configuration.

- Press now button 4 to exit the output configuration menu.

6.3. Minimum/maximum-alarm

This chapter describes how to adjust the device's alarm boundaries for min-/max-alarm-monitoring. This instruction demands that you selected **"AL.F1"** as your desired output function like it is explained in chapter 6.1.

Please note that the alarm-outputs are inverted! This means, that the output will be active when there is no alarm!

- When pressing button 1, the device will be displaying **"AL.Hi"**. (maximum alarm-value)
- Use button 2 or button 3 to set the desired value, the device should turn on its maximum-alarm.
- Press button 1 to validate your selection. The display shows **"AL.Hi"** again.
- When pressing button 1 again, the device will be displaying **"AL.Lo"**. (minimum alarm-value)
- Use button 2 or button 3 to set the desired value, the device should turn on its minimum-alarm
- Press button 1 to validate your selection. The display shows **"AL.Lo"** again.
- When pressing button 1 again, the device will be displaying **"A.dEL"**. (delay of the alarm-function)
- Use button 2 or button 3 to set the desired delay of the alarm-function.

Note: The unit of the value to be set is in [sec.]. The device will turn on the alarm after the minimum or the maximum alarm value was active for the delay-time you have set.

- Press button 1 to validate the delay time. The display shows **"A.dEL"** again.
- When pressing button 1 again, the display shows **"outP"** ('output') again.

Now you have finished the output configuration.

- Press now button 4 to exit the output configuration menu.

7. Switching points and alarm-boundaries (only for GIR 2002)

Remark: The difference between this menu and the output configuration menu is that only in the output configuration menu it is possible to select the output function and to adjust the delay and the preferred state of switching functions.

A change of the input configuration can possibly influence the switching points and alarm boundaries. (e.g. changing of scaling for standard signals or changing of resolution or unit for temperature)

Therefore you may check your output settings after the input configuration has been changed.

General description and notes to the operating of the menu

By means of **button 1** you can go to the next parameter.

Additionally a given changing in the parameter setting can be confirmed by this button and the new value will be saved. Afterwards it will be changed to the parameter view again.

By means of **button 2** and **3** you can go from the parameter view to the parameter setting and adjust its value there.

Hint: The buttons 2 and 3 are featured with a 'roll-function'. When pressing the button once the value will be raised (button 2) by one or lowered (button 3) by one. When holding the button pressed for longer than 1 sec. the value starts counting up or down, the counting speed will be raised after a short period of time. The device also features a 'overflow-function', when reaching the upper limit of the range, the device switches to the lower limit, vice versa.

By means of **button 4** a given changing will be cancelled in the parameter setting. The changing will be discarded and the former parameter value will be preserved.

In the parameter view button 4 closes the menu.

Please note: If you don't press any button for more than 10 sec. in the parameter setting, the adjustment will be cancelled, the changing discarded and it will be changed to the parameter view. If you don't press any button for more than 60 sec. in the menu, the menu will be automatically closed.

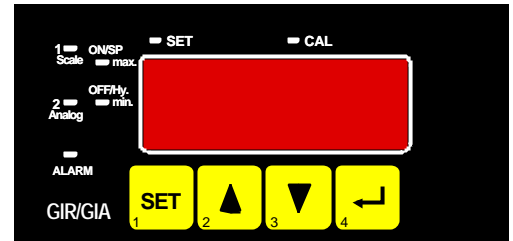

7.1. Menu calling

- When pressing button 1 for >2 seconds the menu to select the switching points and alarm-boundaries will be called.
- Depending on the configuration you have made in the output configuration menu you will get different Display values. Please follow the specific chapter for further information.

Description	Selected as output	Go on in chapter	Note
No output, device is used as displaying device	no	--	Calling of the menu not possible
2-point-controller	2P	7.2	
min-/max-alarm	AL.F1	7.3	

7.2. 2-point-controller

This chapter describes device how to adjust the switching values of the device used as a 2-point-controller. This instruction demands that you selected "2P" as your desired output function like it is explained in chapter 6.1.

- Press button 1 (*if not already done*). The device will be displaying "1.on" (turn-on-point of switching function 1).
- Use button 2 or button 3 to set the desired value, the device's switching function 1 should be turning on.
- Press button 1 to validate your selection. The display shows "1.on" again.
- Press button 1 again, the device will be displaying "1.off". (turn-off-point of switching function 1)
- Use button 2 or button 3 to set the desired value, the device's switching function 1 should be turning off.
- Press button 1 to validate your selection. The display shows "1.off" again.

Example: *You want to control the temperature of a heating coil, with a hysteresis of +2°C, to 120°C. Therefore you will have to select the turn-on-point "1.on" to 120°C and the turn-off-point to "122°C". When your heating coil temperature falls below 120°C it will be turned on. When the temperature rises above 122°C the heating coil will be turned off.*

Note: Depending on the inertia of your heating coil an overshooting of the temperature may be possible.

- When pressing button 1 again, the display shows "1.on" again.

Now you have finished the adjustment of the switching points of the device.

- Press now button 4 to exit the switching point adjustment menu.

7.3. Minimum/maximum-alarm

This chapter describes how to adjust the device's alarm boundaries for min-/max-alarm-monitoring. This instruction demands that you selected "AL.F1" as your desired output function like it is explained in chapter 6.1.

- Press button 1 (*if not already done*). The device will be displaying "AL.Hi". (maximum alarm-value)
- Use button 2 or button 3 to set the desired value, the device should turn on its maximum-alarm.
- Press button 1 to validate your selection. The display shows "AL.Hi" again.
- When pressing button 1 again, the device will be displaying "AL.Lo". (minimum alarm-value)
- Use button 2 or button 3 to set the desired value, the device should turn on its minimum-alarm
- Press button 1 to validate your selection. The display shows "AL.Lo" again.
- When pressing button 1 again, the device will be displaying "A.dEL". (delay of the alarm-function)
- Use button 2 or button 3 to set the desired delay of the alarm-function.

Note: The unit of the value to be set is in [sec.]. The device will turn on the alarm after the minimum or the maximum alarm value was active for the delay-time you have set.

- Press button 1 to validate the delay time. The display shows "A.dEL" again.

Example: *You want to have a temperature alarm-monitoring of a greenhouse. The alarm should start when the temperature rises above 50°C or falls below 15°C.*

Therefore your settings will be 50°C for the maximum alarm-value "AL.Hi" and 15°C for the minimum alarm-value "AL.Lo".

=> The alarm will be starting after the temperature rises above 50°C and stays above 50°C for the entered delay time or after it had been falling below 15°C and stays below 15°C for the entered delay time.

Please note that the alarm-outputs are inverted! This means, that the output will be active when there is no alarm!

- When pressing button 1 again, the display shows "AL.Hi" again.

Now you have finished the adjustment of the alarm boundaries of the device.

- Press now button 4 to exit the alarm boundaries configuration menu.

8. Offset- and slope-adjustment

The offset and slope-adjustment function can be used for compensating the tolerance of the used sensor, and for vernier adjustment of the used transducer or transmitter.

When changing the measuring mode “InP” the values for the offset and slope-adjustment will be reset. Furthermore a change of the device scaling for standard signals (di.Lo, di.Hi) or of the resolution and unit for temperature can possibly influence the values of the offset and slope-adjustment. Therefore the offset- and slope-adjustment should be done after the input configuration has been finished.

Additionally you may check your offset and slope-adjustment after changing the input configuration.

General description and notes to the operating of the menu

By means of **button 1** you can go to the next parameter.

Additionally a given changing in the parameter setting can be confirmed by this button and the new value will be saved. Afterwards it will be changed to the parameter view again

By means of **button 2 and 3** you can go from the parameter view to the parameter setting and adjust its value there.

Hint: The buttons 2 and 3 are featured with a ‘roll-function’. When pressing the button once the value will be raised (button 2) by one or lowered (button 3) by one. When holding the button pressed for longer than 1 sec. the value starts counting up or down, the counting speed will be raised after a short period of time. The device also features a ‘overflow-function’, when reaching the upper limit of the range, the device switches to the lower limit, vice versa.

By means of **button 4** a given changing will be cancelled in the parameter setting. The changing will be discarded and the former parameter value will be preserved.

In the parameter view button 4 closes the menu.

Please note: If you don’t press any button for more than 10 sec. in the parameter setting, the adjustment will be cancelled, the changing discarded and it will be changed to the parameter view. If you don’t press any button for more than 60 sec. in the menu, the menu will be automatically closed.

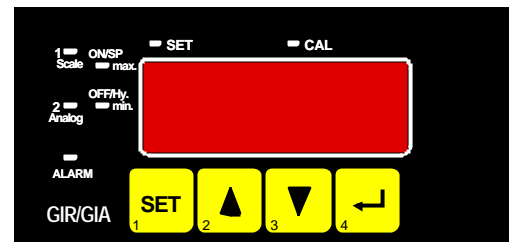

8.1. Menu calling and adjustment

The size of the offset- and slop-menu depends on the selected input signal.

Therefore it could happen that a menu item is not available or that the whole menu can not be called at all.

- Turn on the device and wait after it finished its built-in segment test.
- At the same time press the pushbutton on the rear side (button 5) and button 3 for >2 seconds. The device displays “OFFS” (offset).
- Use button 2 or button 3 for setting the desired zero point offset-value.
The input of the offset will be in digit or °C/°F.
The value that had been set will be subtracted from the measured value. (see below for further information)
- Press button 1 to validate your selection. The display shows “OFFS” again.
- When pressing button 1 again, the device will be displaying “SCAL”. (scale = slope)
- Use button 2 or button 3 to select the desired slope-adjustment.

The slope adjustment will be entered in %. The displayed value is calculated depending on the input signal according to the following formula.

Temperature: $Displayed\ value = (measured\ value - zero\ point\ offset) * (1 + slope\ adjustment\ [\% / 100])$

Standard signal: $Displayed\ value = (measured\ value - zero\ point\ offset - di.Lo) * (1 + slope\ adjustment\ [\% / 100]) + di.Lo$

Example: The setting is 2.00 => the slope has risen 2.00% => slope = 102%.

When measuring a value of 1000 (without slope-adjustment) the device would display 1020 (with slope adjustment of 102%)

- Press button 1 to validate the selection of the slope-adjustment. The display shows “SCAL” again.
- When pressing button 1 again, the display shows “OFFS” again.

Now you have finished the offset- and slope-adjustment.

- Press now button 4 to exit the offset- and slope-adjustment menu.

Examples for offset- and slope-adjustment:Example 1: Connecting a Pt1000-sensor (with an offset error depending on the cable-length of the sensor)

The device displays the following values (without offset- or slope-adjustment): 2°C at 0°C and 102°C at 100°C

Therefore you calculated: zero point: 2

slope: $102 - 2 = 100$ (deviation = 0)

You have to set: offset = 2 (= zero point-deviation)

scale = 0.00

Example 2: Connecting of a 4-20mA-pressure-transducer

The device displays the following values (without offset- or slope-adjustment): 0.08 at 0.00 bar and 20.02 at 20.00 bar

Therefore you calculated: zero point: 0.08

slope: $20.02 - 0.08 = 19.94$

deviation: 0.06 (= target-slope – actual-slope = 20.00 - 19.94)

You have to set: offset = 0.08 (= zero point-deviation)

scale = 0.30 (= deviation / actual-slope = 0.06 / 19.94 = 0.0030 = 0.30%)

Example 3: Connecting of a flow-rate-transducer

The device displays the following values (without offset- or slope-adjustment): 0.00 at 0.00 l/min and 16.17 at 16.00 l/min

Therefore you calculated: zero point: 0.00

slope: $16.17 - 0.00 = 16.17$

deviation: - 0.17 (=target-slope – actual slope = 16.00 - 16.17)

You have to set: offset = 0.00

scale = - 1.05 (= deviation / actual-slope = - 0.17 / 16.17 = - 0.0105 = - 1.05%)

9. Min-/max-value memory:

The device features a minimum/maximum-value memory. In this memory the highest and lowest performance data is saved.

Calling of the minimum-value	press button 3 shortly	the device will display “Lo“ briefly, after that the min-value is displayed for about 2 sec.
Calling of the maximum-value	press button 2 shortly	the device will display “Hi“ briefly, after that the max-value is displayed for about 2 sec.
Erasing of the min/max values	press button 2 and 3 for 2 sec.	The device will display “CLr“ briefly, after that the min/max-values are set to the current displayed value.

10. Serial interface:

The device features one **EASY**bus-Interface. You can use the device as a full function **EASY**bus-device. The serial interface allows the device to communicate with a host computer. Data polling and data transfer is done in master/slave mode, so the device will only send data on demand. Every device has a unique ID-number that makes exact identification of each device possible. With the help of a software (like EbxKonfig – freeware version available via internet) you are able to reassign an address to the device.

Additional accessories needed for the interface mode:- Level converter **EASY**bus ⇔ PC: e.g. EBW1, EBW64, EB2000MC

- Software for communication with the device

EBS9M: 9-channel-software for displaying a measured value.

EASYCONTROL: multi-channel software for real-time-recording and displaying measure-values of a device in ACCESS®-database-format.

EASYBUS-DLL: EASYBUS-developer-package for developing own software. This package features a universal WINDOWS®-Library with documentation and program-examples. The DLL can be used in any usual programming language.

11. Alarm display (only for GIR 2002)

If an output function with min-/max-alarm (out = AL.F1) is selected, LEDs will display the min-/max-alarm in case of its appearance.

Min-alarm: LEDs "alarm" and "min" glow

Max-alarm: LEDs "alarm" and "max" glow

If a system-alarm or system-error occurs, it will be handled like a min- and max-alarm. In this case the LEDs "min", "max" and "alarm" will glow. Additionally the error code will be displayed.

12. Error codes

When detecting an operating state which is not permissible, the device will display an error code

The following error codes are defined:

Err.1: Exceeding of the measuring range

Indicates that the valid measuring range of the device has been exceeded.

Possible causes:

- Input signal to high.
- Sensor broken (Pt100 and Pt1000).
- Sensor shorted (0(4)-20mA).
- Counter overflow.

Remedies:

- The error-message will be reset if the input signal is within the limits.
- check sensor, transducer or transmitter.
- check device configuration (e.g. input signal)
- reset the counter.

Err.2: Values below the measuring range

Indicates that the values are below the valid measuring range of the device.

Possible causes:

- Input signal is too low or negative.
- Current below 4mA.
- Sensor shorted (Pt100 and Pt1000).
- Sensor broken (4-20mA).
- Counter underflow.

Remedies:

- The error-message will be reset if the input signal is within the limits.
- Check sensor, transducer or transmitter.
- check device configuration (e.g. input signal)
- Reset the counter.

Err.3: Display range has been exceeded

Indicates that the valid display range (9999 digit) of the device has been exceeded.

Possible causes:

- Incorrect scale.
- Counter overflow.

Remedies:

- The error-message will be reset if the display value is below 9999.
- Reset the counter.
- When happening frequently, check the scale-setting, maybe it was set too high and should be reduced.

Err.4: Values below display range

Indicates that display value is below the valid display range of the device (-1999 digit).

Possible causes:

- Incorrect scale.
- Counter underflow.

Remedies:

- The error-message will be reset if the display value is above -1999.
- Reset the counter
- When happening frequently, check the scale-setting, maybe it was set too low and should be increased.

Err.7: System-error

The device features an integrated self-diagnostic-function which checks essential parts of the device permanently. When detecting a failure, error-message Err.7 will be displayed.

Possible causes:

- Valid operating temperature has exceeded or has fallen below the valid temperature range.
- Device defective.

Remedies:

- Stay within valid temperature range.
- Exchange the defective device.

Err.9: Sensor defective

The device features an integrated diagnostic-function for the connected sensor or transmitter. When detecting a failure, error-message Err.9 will be displayed.

Possible causes:

- Sensor broken or shorted (Pt100 or Pt1000).
- Sensor broken (thermo-elements).

Remedies:

- Check sensor or exchange defective sensor.

Er.11: Value could not be calculated

Indicates a measuring value, needed for calculation of the display value, is faulty or out of range.

Possible causes:

- Incorrect scale.

Remedies:

- Check settings and input signal.

Er.12: Invalid value, incorrect configuration

Indicates that the configuration of the device has been done incorrectly and that it has not been possible to calculate a valid display.

Possible causes:

- Incorrect configuration of the device.

Remedies:

- Check configuration of device.

cccc: Incomplete input configuration

Indicates that the configuration of the measuring input has not been done completely.

Possible causes:

- Configuration of the measuring input incomplete.

Remedies:

- Configure the measuring input completely.

13. Specification

Absolute maximum ratings: see chapter 3.2. (Connection data)

Measuring inputs: Standard inputs for

Input type	Signal	Range	Resolution	Note
Standard-voltage-signal	0 – 10 V	0 ... 10 V		$R_i \geq 200 \text{ k}\Omega$
	0 – 2 V	0 ... 2 V		$R_i \geq 10 \text{ k}\Omega$
	0 – 1 V	0 ... 1 V		$R_i \geq 10 \text{ k}\Omega$
	0 – 50 mV	0 ... 50 mV		$R_i \geq 10 \text{ k}\Omega$
Standard-current-signal	4 – 20 mA	4 ... 20 mA		$R_i = \sim 125 \text{ }\Omega$
	0 – 20 mA	0 ... 20 mA		$R_i = \sim 125 \text{ }\Omega$
RTD probes	Pt100	-50.0 ... +200.0 °C (-58.0 ... +392.0 °F)	0.1 °C / °F	3-wire-connection max. perm. line resistance: 20 Ohm
		-200 ... +850 °C (-328 ... +1562 °F)	1 °C / °F	
	Pt1000	-200 ... +850 °C (-328 ... +1562 °F)	1 °C / °F	2-wire-connection
Thermocouple probes	NiCr-Ni (Type K)	-70.0 ... +250.0 °C (-94.0 ... +482.0 °F)	0.1 °C / °F	
		-270 ... +1372 °C (-454 ... +2502 °F)	1 °C / °F	
	Pt10Rh-Pt (Type S)	-50 ... +1750 °C (-58 ... +3182 °F)	1 °C / °F	
	NiCrSi-NiSi (Type N)	-100.0 ... +300.0 °C (-148.0 ... +572.0 °F)	0.1 °C / °F	
		-270 ... +1350 °C (-454 ... +2462 °F)	1 °C / °F	
	Fe-CuNi (Type J)	-70.0 ... +300.0 °C (-94.0 ... +572.0 °F)	0.1 °C / °F	
		-170 ... +950 °C (-274 ... +1742 °F)	1 °C / °F	
	Cu-CuNi (Type T)	-70.0 ... +200.0 °C (-94.0 ... +392.0 °F)	0.1 °C / °F	
-270 ... +400 °C (-454 ... +752 °F)		1 °C / °F		
Frequency	TTL-Signal	0 Hz ... 10 kHz	0.1 mHz	<i>signal low: 0.0 – 0.5 V signal high: 2.7 – 24 V</i>
	Switching contact NPN	0 Hz ... 3 kHz	0.1 mHz	<i>An internal pull-up-resistor (~11 kOhm to +3.3V) is connected automatically.</i>
	Switching contact PNP	0 Hz ... 1 kHz	0.1 mHz	<i>An internal pull-down-resistor (~11 kOhm to GND) is connected automatically.</i>
Rotation	TTL-Signal, Switching contact NPN, PNP	0 ... 9999 U/min	0.001 U/min	Pre-scaling-factor (1-1000), Pulse-frequency: max. 600000 p./min. *
Up/Downwards - Counter	TTL-Signal, Switching contact NPN, PNP	0 ... 9999 with pre-scaling factor: 9 999 000		Pre-scaling-factor (1-1000) Pulse-frequency: max. 10000 p./sec. *
	Counter reset input	--		Reset: $R < 1 \text{ k}\Omega$ Enable: $R > 100 \text{ k}\Omega$

* = with switching contact accordingly to frequency input lower values may occur

Display range:	(voltage-, current and frequency-measurement) -1999 ... 9999 digits, initial value, terminal value and decimal point position arbitrary. Recommended range: < 2000 Digit
Accuracy: (at nominal temperature)	
Standard-signals:	< 0.2% FS \pm 1Digit (from 0 – 50mV: < 0.3% FS \pm 1Digit)
RTD:	< 0.5% FS \pm 1Digit
Thermocouples:	< 0.3% FS \pm 1Digit (from Type S: < 0.5% FS \pm 1Digit)
Frequency:	< 0.2% FS \pm 1Digit
Point of compensation:	\pm 1°C \pm 1Digit (at nominal temperature)
Temperature drift:	< 0.01% FS / K (from Pt100 – 0.1°C: < 0.015% FS / K)
Measuring freq.:	approx. 100 measures / sec. (standard-signal) or approx. 4 measures / sec. (temperature-measurement) or approx. 4 measures / sec. (frequency, rpm at $f \geq 4$ Hz) or accordingly f (at $f < 4$ Hz)
Display:	approx. 13 mm height, 4-digit red LED-display
Operating:	4 push-buttons or via interface
Interface:	EASY bus-interface, electrically isolated
Transmitter supply:	24 V _{DC} \pm 5%, 20mA, electrically isolated <i>or the corresponding designation on the label on the housing</i>
Outputs:	1 volt-free Relay-outputs * ² (standard) <i>or the corresponding designation on the label on the housing</i> 1 analog output, electrically isolated
Output 1 *²:	change-over contact, breaking capacity: 10A (ohmic load), 250 V _{AC}
Response Time:	\leq 25 msec. for standard signals \leq 0.5 sec. for temperature, frequency ($f > 4$ Hz)
Output-functions:	2-point, min-/max-alarm
Switching points:	arbitrary
Analog output:	0-20 mA (AAG420), 4-20 mA (AAG420) or 0-10V (AAG010) <i>or the corresponding designation on the label on the housing</i>
Scaling:	arbitrary
Accuracy:	0.2 % FS
Min. permissible load:	1000 Ohm (at AAG010)
Max. perm. burden:	300 Ohm (at AAG420, AAG020)
Power supply:	230 V _{AC} , 50/60 Hz (standard) <i>or the corresponding designation on the label on the housing</i>
Nominal temp.:	25°C
Operating ambient:	-20 to +50°C
Relative humidity:	0 to 80% RH (non condensing)
Storage temp.:	-30 to +70°C
Housing:	
Dimensions:	48 x 96 mm (front-panel dimensions).
Installation depth:	approx. 115 mm (incl. screw-in/plug-in clamps)
Panel Mounting:	with brackets
Panel cut-out:	43.0 ^{+0.5} x 90.5 ^{+0.5} mm (H x W)
Connection:	via screw-in/plug-in clamps Conductor cross-selection from 0.14 to 1.5 mm ²
Protection class:	front IP54, with optional mounting seals IP65
EMC:	EN61326 +A1 +A2 (appendix A, class B), additional errors: < 1% FS When connecting long leads adequate measures against voltage surges have to be taken.

*² = *not available at GIA 2000*

14. Disposal notes

This device must not be disposed as 'residual waste'.

To dispose this device, please send it directly to us (adequately stamped). We will dispose it appropriately and environmentally friendly.

15. Special functions (optionally):

15.1. Tare function

Optionally the device may have a tare function. The display value can be set to 0 by means of this function. The display then is calculated relatively to the tare value.

Setting the tare function: press key 4 shortly the display value will be set to 0

Clearing the tare function: press key 4 for ~4 seconds the current measuring value is displayed again.

The LED "CAL" is indicating an active tare function.

Note: Calling the tare function at a current measuring value of 0 is not possible.

If a tare function is already active when pressing the key 4 at display value 0, then the tare function will be cleared.