



Manual for connection and operating of

GRA 0420 WK

GRA 010 WK

as of version 1.0



WEEE-Reg.-Nr. DE93889386

INDEX

1	INTRODUCTION	2
2	SAFETY REGULATIONS	3
3	ELECTRIC CONNECTION	4
3.1	Connection assignment for GRA 0420 WK / GRA 010 WK:	4
3.2	Connection example:	4
3.2.1	GRA...WK: switching of a relay	4
3.2.2	Connection example: switching of a relay with combined supply for measurement section and output section	4
4	CONFIGURATION: (DISPLAY ADJUSTMENT TO THE TRANSMITTER)	5
4.1	Configuration of the input signal	5
4.2	Selection of the output function	6
5	SWITCHING POINTS / ALARM-BOUNDARIES:	7
5.1	2-point-controller	7
5.2	Min-/Max-Alarm	8
6	OFFSET- AND SLOPE-ADJUSTMENT	9
7	MIN-/MAX-VALUE STORAGE	9
8	ERRORCODES:.....	10
9	SPECIFICATION.....	11
10	DISPOSAL INSTRUCTIONS.....	11

1 Introduction

The GRA0420WK and GRA010WK is a microprocessor controlled displaying, monitoring and controlling device.

In according to his type the device is supporting an input for:

- standard signal 4 – 20 mA (GRA0420WK)
- standard signal 0 – 10 V (GRA010WK)

The device features one switching output (npn-output), which can be configured as 2-point-controller or min./max. alarm output.

The state of the switching output is displayed with the LED left beneath the LED-display.

When leaving our factory the GRA...WK has been subjected to various inspection tests and is completely calibrated.

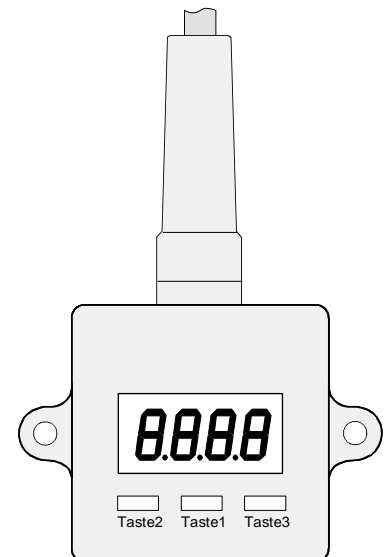

Before the GRA...WK can be used, it has to be configured for the customer's application.

2 Safety regulations

This device was designed and tested considering the Safety regulations for electronic measuring devices. Faultless operation and reliability in operation of the measuring device can only be assured if the General Safety Measures and the devices specific safety regulation mentioned in this users manual are considered.

1. Faultless operation and reliability in operation of the measuring device can only be assured if the device is used within the climatic conditions specified in the chapter "Specifications".
2. Always disconnect the device from its supply before opening it. Take care that nobody can touch any of the unit's contacts after installing the device.
3. Standard regulations for operation and safety for electrical, light and heavy current equipment have to be observed, with particular attention paid to the national safety regulations (e.g. VDE 0100).
4. When connecting the device to other devices (e.g. the PC) the interconnection has to be designed most thoroughly, as internal connections in third-party devices (e.g. connection of ground with protective earth) may lead to undesired voltage potentials.
5. The device must be switched off and must be marked against using again, in case of obvious malfunctions of the device which are e.g.:
 - visible damage
 - no prescribed working of the device
 - storing the device under inappropriate conditions for longer time

When not sure, the device should be sent to the manufacturer for repairing or servicing.

6. This device must not be used at potentially explosive areas! The usage of this device at potentially explosive areas increases danger of deflagration, explosion or fire due to sparking.
7. This device is not constructed for use in medical applications.
8. This device must not be run with a defective or damaged power supply unit. Danger to life due to electrical shock!



Attention: When running electric devices, parts of them will always be electrically live. Unless the warnings are observed serious personal injuries or damage to property may result. Skilled personnel only should be allowed to work with this device. For trouble-free and safe operation of the device please ensure professional transport, storage, installation and connection as well as proper operation and maintenance.

Skilled personnel

are persons familiar with installation, connection, commissioning and operation of the product and have professional qualification relating to their job.

For example:

- Training or instruction resp. qualifications to switch on or off, isolate, ground and mark electric circuits and devices or systems.
- Training or instruction according to the state.
- First-aid training.

ATTENTION:

Do NOT use this product as safety or emergency stopping device, or in any other application where failure of the product could result in personal injury or material damage.

Failure to comply with these instructions could result in death or serious injury and material damage.

3 Electric connection

The connection of the GRA...WK occurs via 4-conductor respectively 5-conductor connector cable.

Supply voltage: GRA 0420 WK device takes power directly from measuring current
GRA 010 WK 12 ... 28 V or according device declaration

Electric connection and commissioning of the device must be carried out by trained and skilled personnel. Wrong connection may lead to the destruction of the device, in which case we cannot assume any warranty. ! Mind for the GRA0420WK the maximum input current rating of 40mA under any circumstances!

3.1 Connection assignment for GRA 0420 WK / GRA 010 WK:

contact-number	wire colour	GRA 0420 WK	GRA 010 WK
1	white	signal +	supply +
2	brown	signal -	supply -, GND
3	grey	---	signal +
4	green	switching output +	switching output +
5	yellow	switching output -	switching output -

3.2 Connection example:

Please take care that you must not exceed the limits of the voltage and of the maximum current of the switching outputs (not even for a short period of time). Please take extreme care when switching inductive loads (like coils or relays, etc.) because of their high voltage peaks, protective measures to limit these peaks have to be taken.

When switching large capacitive loads a series resistor for current limitation needed, because of the high turn-on-current of high capacitive loads. The same applies to incandescent lamps, whose turn-on-current is also quite high due to their low cold resistance.

3.2.1 GRA...WK: switching of a relay

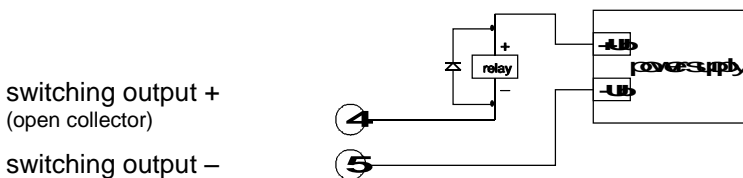

3.2.2 Connection example: switching of a relay with combined supply for measurement section and output section

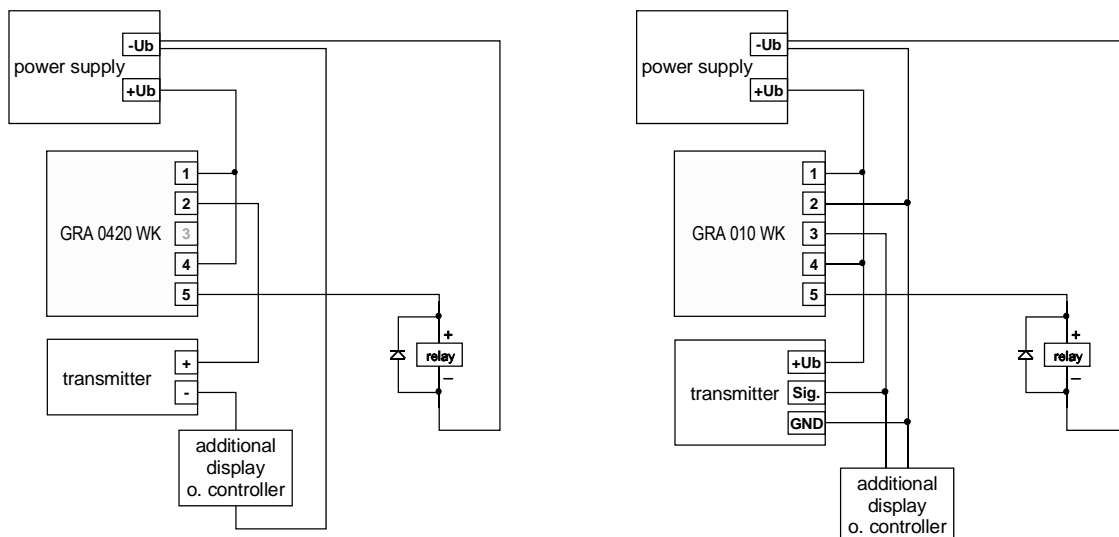

4 Configuration: (display adjustment to the transmitter)

Please note: The storage of a configuration value will be done by switching to the next configuration value (via button 1).

When configuration is active and no button is pressed for more than 60 seconds the configuration will be cancelled. Stored changes will not be lost!

Hint: The buttons 2 and 3 are featured with a 'roll-function'. When pressing the button once the value will be raised (button 2) by one or lowered (button 3) by one.

When holding the button pressed for longer than 1 second the value starts counting up or down, the counting speed will be raised after a short period of time.

4.1 Configuration of the input signal

- Turn the device on and wait until it completed its built-in segment test.
- Press button 2 for 1 second
In the device display appears ,dP' (decimal point).
- Select the desired decimal point place by pressing button 2 respective button 3.
- Validate the selected value by pressing button 1. The display shows ,dP' again.
- Press button 1 again, the display will show "**di.Lo**" (Display Low = low display value).
- Use button 2 and button 3 to select the desired value the device should display when a 4mA resp. 0V input signal is attached.
- Validate the selected value by pressing button 1. The display shows "**di.Lo**" again.
- Press button 1 again, the display will show "**di.Hi**" (Display High = high display value).
- Use button 2 and button 3 to select the desired value the device should display when a 20mA resp. 10V input signal is attached.
- Validate the selected value by pressing button 1. The display shows "**di.Hi**" again.
- Press button 1 again. The display will show "**Li**" (Limit = Measuring range limit).
- Use button 2 and button 3 to select the desired measuring range limit.

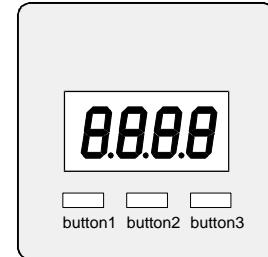

Display	Measuring range limit	Notes
off	Deactivated	Exceeding of the measuring range limit is tolerable as of the measuring limit (p.r.t. hint).
on.Er (on error)	Active, (displays error)	The meas. range limit is exactly bounded by the input signal. When exceeding or shortfailing the input signal an error message will be displayed.
on.rG (on range)	Active, (displays the selected limit)	The meas. range limit is exactly bounded by the input signal. When exceeding or shortfailing the input signal the device will display the selected lower/upper display value. [e.g. humidity: when shortfailing or exceeding, the device will display 0% or 100%]

Hint: When exceeding the measuring limit independently from the setting, the device will always display an error message ("Err.1" or "Err.2").

The measuring limit are by 3.7 and 20.8 mA respective. 10.5 V (a falling bellow 0V will not detected)

- Press button 1 to validate the selection, the display shows "**Li**" again.
- When pressing button 1 again, the display will show "**FiLt**" (Filter).
- Use button 2 and button 3 to select the desired filter behaviour
 - 0 = filter deactivated
 - 1 = filter stage 1: suppresses jumping display values caused be smallest changes
 - 2 = filter stage 2: additional suppression of measuring peaks (causes delayed reaction of switching output)
- Press button 1 to validate your value, the display shows "**FiLt**" again.

The configuration of the device to the input signal is now completed. You now have to configure the output of the device.

4.2 Selection of the output function

- When pressing button 1 again, the display will show “**outP**”. (Output)
- Use button 2 and button 3 (middle or right button) to select the desired output-function.

Description	to select as output	Output (out)	see chapter
no output, device is used as display	no	off	--
2-point-controller	2P	switching function	5.1
3-point-controller	AL	min-/max-alarm, inverse	5.2

- Press button 1 to validate the selected output function. The display shows “**outP**” again.

For output function = no the configuration is now finished. Press button 1 to finish the adjustment and to switch over to display the measuring value.

If the output function was changed here, the delay and preferred state of switching function and the switching points / alarm-boundaries are to configured in following.

The settings described in the following depend on the output function. Depending on this setting therefore it is possible that more than one point are present in the following.

- When pressing button 1 again, the device will display “**1.dEL**” (delay = delay of switching function).
- Use button 2 and button 3 to set the desired value for the switching-delay.
Hint: the selected value [0.01 ... 2.00] accords the switching delay in seconds.
- Press button 1 to validate the selection. The display shows “**1.dEL**” again.
- When pressing button 1 again, the device will display “**1.Err**” (error = preferred state of switching function).
- Use button 2 and button 3 to set the desired initial state in case of an error.

Display	Preferred state of the output	Note
off	Inactive in case of an error	
on	Active in case of an error	

- Press button 1 to validate the selection. The display shows “**1.Err**” again.

The configuration of the output function is now completed. Depending on the selected output function you have to make the settings for switching / alarm points. See description in chapter „switching points / alarm-boundaries“ for further information.

Hint: The settings for the switching and alarm points can be made later in an extra menu (see chapter 5)

5 Switching points / alarm-boundaries:

Please note: The storage of a configuration value will be done by switching to the next configuration value (via button 1).

When configuration is active and no button is pressed for more than 60 seconds the configuration will be cancelled. Stored changes will not be lost!

Hint: The buttons 2 and 3 are featured with a 'roll-function'. When pressing the button once the value will be raised (button 2) by one or lowered (button 3) by one.

When holding the button pressed for longer than 1 second the value starts counting up or down, the counting speed will be raised after a short period of time.

- When pressing button 1 for >2 seconds the menu to select the switching points and alarm-boundaries will be called.
- Depending on the configuration you have made in the „output“ menu you will get different display values. Please follow the specific chapter for further information.

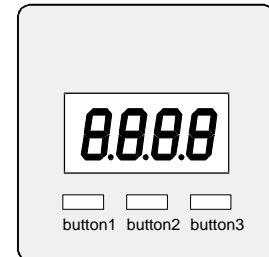

Description	to select as output	Output (out)	see chapter
no output, device is used as display	no	off	--
2-point-controller	2P	switching function	5.1
3-point-controller	AL	min-/max-alarm, inverse	5.2

5.1 2-point-controller

This chapter describes how to configure the switching points as use the device for a 2-point-controller. This instruction demands that you selected "**2P**" as your desired output function.

- Press button 1 (when not already done). The device will display "**1.on**" (turn-on-point)
- Use button 2 and button 3 to set the desired value, the device's output should be turning on.
- Press button 1 to validate your selection. The display shows "**1.on**" again.
- When pressing button 1 again, the device will display "**1.off**". (turn-off-point)
- Use button 2 and button 3 to set the desired value, the device's output 1 should be turning off.
- Press button 1 to validate your selection. The display shows "**1.off**" again.

Example: You want to control the temperature of a heating coil, with a hysteresis of +2°C, to 120°C. Therefore you will have to select the turn-on-point "1.on" to 120°C and the turn-off-point to "122°C". When your heating coil temperature falls below 120°C it will be turned on. When the temperature rises above 122°C the heating coil will be turned off.

Note: Depending on the inertia of your heating coil an overshooting of the temperature may be possible.

Now you finished configuring the switching point adjustment of your device. Press button 1 to finish the adjustment and to switch over to display the measuring value

5.2 Min-/Max-Alarm

This chapter describes how to configure the device's alarm boundaries for min-/max-alarm-monitoring. This instruction demands that you selected "**AL**" as your desired output function.

- Press button 1 (*when not already done*) , the device will display "**AL.Hi**". (maximum alarm-value)
- Use button 2 and button 3 to set the desired value, the device should turn on its maximum-alarm.
- Press button 1 to validate your selection. The display shows "**AL.Hi**" again.
- When pressing button 1 again, the device will display "**AL.Lo**". (minimum alarm-value)
- Use button 2 and button 3 to set the desired value, the device should turn on its minimum-alarm
- Press button 1 to validate your selection. The display shows "**AL.Lo**" again.
- When pressing button 1 again, the device will display "**A.dEL**". (delay of the alarm-function)
- Use button 2 and button 3 to set the desired delay of the alarm-function.

Note: the selected value [0 ... 9999] accords the alarm delay in seconds.

The device will turn on the alarm after minimum or maximum alarm value was active for the delay-time you have set.

- Press button 1 to validate the delay time. The display shows "**A.dEL**" again.

Example: *You want to have a temperature alarm-monitoring of a greenhouse. The alarm should start when the temperature rises above 50°C or falls below 15°C.*

Therefore your settings will be 50°C for the maximum alarm-value "AL.Hi" and 15°C for the minimum alarm-value "AL.Lo".

The alarm will be starting after the temperature rises above 50°C and stays above 50°C for the entered delay time or after it had been falling below 15°C and stays below 15°C for the entered delay time.

Please note that the alarm-outputs are inverted! This means, that the output will be active when there is no alarm!

Now you finished configuring the alarm adjustment of your device. Press button 1 to finish the adjustment and to switch over to display the measuring value.

6 Offset- and slope-adjustment

The offset and slope-adjustment function can be used for compensating the tolerance of the used sensor, resp. for vernier adjustment of the used transducer / transmitter.

Please note: *The storage of a configuration value will be occur by switching to the next configuration value (via button 1).
When configuration is active and no button is pressed for more than 60 seconds the configuration will be cancelled. Stored changes will not be lost!*

Hint: *The buttons 2 and 3 are featured with a 'roll-function'. When pressing the button once the value will be raised (button 2) by one or lowered (button 3) by one.
When holding the button pressed for longer than 1 second the value starts counting up or down, the counting speed will be raised after a short period of time*

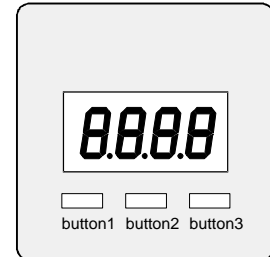

- Turn on the device and wait after it finished its built-in segment test.
- Press button 3 > 2 seconds
The device will display "**OFFS**" (Offset).
- Use button 2 and button 3 for setting the desired zero point offset-value.
*The input of the offset value are in digit.
The value that had been set will be subtracted from the measured value. (see below for further information)*
- Press button 1 to validate your selection. The display shows "**OFFS**" again.
- When pressing button 1 again, the device will display "**SCAL**". (scale = slope)
- Use button 2 and button 3 to select the desired slope-adjustment.
*The slope adjustment will be entered in %. The value displayed can be calculated like this:
Display = (measured value – offset – di.Lo) * (1 + slope adjustment [% / 100]) + di.Lo*
- Example: The setting is 2.00 => the slope has risen 2.00% => slope = 102%.
When measuring a value of 1000 (without slope-adjustment) the device would display 1020 (with slope adjustment of 102%)*
- Press button 1 to validate the selection of the slope-adjustment. The display shows "**SCAL**" again.

Now you finished the offset and slope adjustment of your device.

Press button 1 to finish the adjustment and to switch over to display the measuring value.

Examples for offset- and slope-adjustment:

Example: *Connecting of a pressure-transducer*

The device displays the following values (without offset- or slope-adjustment): 0.08 at 0.00 bar and 20.02 at 20.00 bar

Therefore you calculated: zero point: 0.08

slope: 20.02 – 0.08 = 19.94

deviation: 0.06 (= target-slope – actual-slope = 20.00 - 19.94)

You have to set: offset = 0.08 (= zero point-deviation)

scale = 0.30 (= deviation / actual-slope = 0.06 / 19.94 = 0.0030 = 0.30%)

7 Min-/max-value storage

The device features a minimum/maximum-value storage. In this storage the highest and lowest performance data is saved.

Calling of the minimum-value press button 3 shortly

Calling of the maximum-value press button 2 shortly

Erasing of the min/max values press button 2 and 3 for 2 sec.

the device will display "Lo" briefly, after that the min-value is displayed for about 2 sec.
the device will display "Hi" briefly, after that the max-value is displayed for about 2 sec.
The device will display "CLr" briefly, after that the min/max-values are set to the current displayed value.

8 Errorcodes:

When detecting an operating state which is not permissible, the device will display an error code.

The following error codes are defined:

Err.1: Exceeding of the measuring range

Indicates that the valid measuring range of the device has been exceeded.

Possible causes:

- Input signal to high
- Sensor shorted (0(4)-20mA)

Remedies:

- The error-message will be reset if the input signal is within the limits.
- check transmitter and device configuration (e.g. input signal).

Err.2: Values below the measuring range

Indicates that the values are below the valid measuring range of the device.

Possible causes:

- Input signal is too low or negative
- Current below 4mA
- Sensor broken (4-20mA)

Remedies:

- The error-message will be reset if the input signal is within the limits.
- check transmitter and device configuration (e.g. input signal).

Err.3: Display range has been exceeded

Indicates that the valid display range (9999 digit) of the device has been exceeded.

Possible causes:

- Incorrect scale

Remedies:

- The error-message will be reset if the display value is below 9999.

Err.4: Values below display range

Indicates that display value is below the valid display range of the device (-1999 digit).

Possible causes:

- Incorrect scale

Remedies:

- The error-message will be reset if the display value is above -1999.

Err.7: System-error

The device features an integrated self-diagnostic-function which checks essential parts of the device permanently. When detecting a failure, error-message Err.7 will be displayed.

Possible causes:

- Valid operating temperature range has been exceeded or is below the valid temperature range
- Device defective

Remedies:

- Stay within valid temperature range
- Exchange the defective device.

Er.11: Value could not be calculated

Indicates a measuring value, needed for calculation of the display value, is faulty or out of range.

Possible causes:

- Incorrect scale

Remedies:

- Check settings and input signal

9 Specification

	GRA 0420 WK...	GRA 010 WK...
Input signal:	4 ... 20 mA (2-wire)	0 ... 10V (3-wire)
Voltage load:	< 5.5 V	
Input resistance:		ca. 30 kOhm
max. permissible input:	25 mA (40mA short-time)	20 V
Supply voltage:		12 - 28 V
Supply current:	from current loop	< 10 mA
Display:	approx. 7 mm high, 4-digit LED-display	
Display range:	first and last value freely adjustable	
max. display value:	9999 digit	
min. display value:	-1999 digit	
recommended range:	≤ 2000 digit	
Decimal point:	any position	
Accuracy: (at 25°C)	< 0.2% ±1 digit	
Measuring rate:	approx. 50 measurements / second	
Filter:	selectable in 3 stages	
Operation:	via 3 buttons	
Min-/Max-value memory:	via buttons selectable	
Switching outputs:	1 electrically isolated open collector output	
Test voltage:	50V	
Switching point, hysteresis:	freely adjustable	
Switching voltage:	max. 28V	
Switching current:	max. 20mA (optionally: 50mA)	
	<i>Please note: the switching output is not short-circuits protected</i>	
Reaction time:	≤ 20 ms	
Connection output:	via cable	
Nominal temperature:	25°C	
Working temperature:	-25 ... 50°C	
Relative humidity:	0 ... 80% (non-condensing)	
Storage temperature:	-20 ... 70°C	
Electrical connection:	4-wire resp. 5-wire cable, approx. 2m length	
Housing:	ABS, keypad	
	approx. 48.5 x 48,5 x 35.5 mm (L x W x D) without PG-screwing	
Protection rating:	front IP65 (when mounted appropriately)	
Directives / standards:	The instruments confirm to following European Directives:	
	2014/30/EU	EMC Directive
	2011/65/EU	RoHS
	Applied harmonized standards:	
	EN 61326-1 : 2013	emissions level: class B
		emi immunity according to table 2
		Additional fault: <1%
		<i>When connecting long leads adequate measures against voltage surges have to be taken</i>
	EN 50581 : 2012	

10 Disposal instructions

The device must not be disposed in the regular domestic waste.

Send the device directly to us (sufficiently stamped), if it should be disposed. We will dispose the de-vice appropriate and environmentally sound.

