

Connecting and Operating Manual

GIR1002 NS-S/T

Version: 4.06

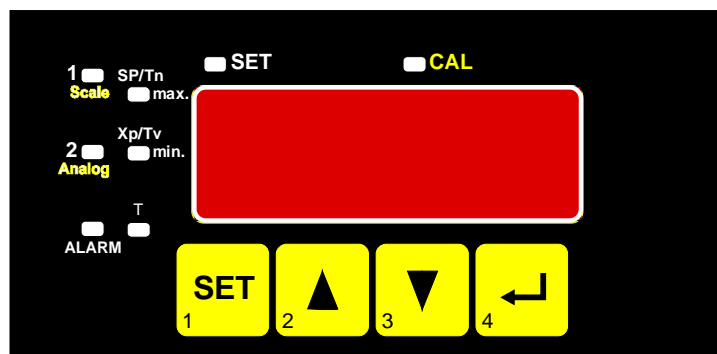

In accordance with
EN50081-1 and EN50082-2
for unrestricted use in
housing and industrial areas

This connecting and operating manual may be subject to technical alternations.

Index

Introduction	page: 3
Safety Regulations	page: 3
Electric Connection	page 4
TerminalAssignment	page: 4
Assignment Diagram	page: 4
Transmitter Connection	page: 5
Technical Specifications	page: 5
Operation	page: 6
Start-up	page: 6
Table of functions	page: 6
Display of current measuring value	page: 6
Alarm reset	page: 6
Display of max. value	page: 6
Max. value reset	page: 7
Display of min. value	page: 7
Min. value reset	page: 7
Display/setting of switching point (set point value)	page: 7
Display/setting of proportional band (Xp)	page: 7
Display/setting of integral time (Tn)	page: 7
Display/setting of derivative time (Tv)	page: 8
Display/setting of cycle time (T)	page: 8
Display/setting of max. alarm limit	page: 8
Display/setting of min. alarm limit	page: 8
Display/setting of alarm delay	page: 8
Configuration	page: 9
Fault Codes	page: 11
RS485 interface	page: 12
Interface configuration	page: 12
Data transfer format	page: 12
Data transfer processing protocol	page: 12
Description of characters used	page: 13
Functional code	page: 14
Dataformat	page: 15
Annex A:	page: 17
Practical advice for setting the GIR1002 NS-S/T when using it as heating controller	page: 17

Introduction

The following manual gives a description for the connection and operation of the device GIR1002 NS-S/T. The GIR1002 NS is a micro-processor controlled standard signal controller for universal applications. It can be used for the connection of 0 to 20mA, 4 to 20mA, 0 to 1V and 0 to 10V standard signals.

The large 4-digit numeric LED as well as seven additional LEDs ensure a clear and well legible display of all measuring values and operating parameters.

The GIR1002 NS-S/T is designed for direct connection of a transmitter (measuring transducer). The controller range is adapted to the transmitter by directly entering the upper and lower measuring range limits, i.e. no external devices being necessary.

All parameters and limit values can be entered via four buttons located at the front side of the device.

The front side of the controller is splash water and wipe resistant fulfilling all requirements of the IP65 rating.

All programmable parameters of the GIR1002 NS-S/T are stored in an EEPROM and in case of a current failure they will be safe for at least ten years.

The GIR1002NS-S/T is equipped with a self-diagnosis function constantly monitoring the essential parts of the controller for their trouble-free operation. Together with the self-diagnosis function the monitoring functions for "breaking of the measuring sensor" and "sensor short-circuit" as well as values falling below or exceeding the limited range ensure optimum operational reliability.

We will supply the GIR1002 NS-S/T factory tested and completely calibrated.

Before you can actually use it, make sure to configurate your GIR1002 NS-S/T for your special application. Please also refer to the chapter "Configuration".

Safety Regulations

In order to exclude any risk whatever for the operator the following points have to be observed:

- a) Immediately switch off the device in case of visible damage or obvious malfunctions.
- b) Make it a rule to always disconnect voltage source and device before opening it up. The entire device and its connection have to be fingerproof after installation.
- c) Standard regulations for operation and safety for electrical. light and heavy current equipment have to be observed, with particular attention having to be paid to national safety regulations (e.g. VDE 0100).
- d) When connecting the GIR 1002 NS-S/T to other devices (e.g. PC), the interconnection has to be designed most thoroughly as internal. Connections in third-party devices (e.g. connection GND with protective earth) may lead to undesired voltage potentials.



Attention: When running electric devices parts of these devices will always be highly energised. Unless the warnings are observed serious personal injuries or damage to property may result. Skilled personnel only should be allowed to work with this device. For trouble-free and safe operation of the device please ensure professional transport, storage, installation and connection as well as proper operation and maintenance.

Skilled personnel

are persons familiar with installation, connection, commissioning and operation of the product and have a professional qualification relating to their job.

For example:

- Training or instruction and/or qualification to switch on/off, isolate, ground and mark electric circuits and devices/systems.
- Training or instruction according to the state of the art of safety technology to maintain and operate adequate safety equipment.
- First-aid training.

Electric Connection

All connections for the GIR1002 NS-S/T are located at the back side of the device.

Connections are made via screw-type/plug-in terminals.

Make it a rule to mount screw-type/plug-in terminals while they are still loose and to put them on only afterwards. When mounting terminals already put on there is a risk that soldering eyelets may be pulled out. Please use suitable screw driver and do not tighten screws by force.

Supply Voltage : 230V AC, 50/60Hz or instruction on the device

Please make sure that the mains voltage applied corresponds to the supply voltage stated on the device

Switching output: 1 potential-free relay (changeover contact)
1 potential-free relay (make-contact)

Switching capacity: 10A, 250V AC (ohmic load)

When using inductives loads the contact has to be conected to a suitable RC-element (for example 'RC220').

Electric connection and commissioning of the device must be carried out by trained and skilled personnel. Wrong connection may lead to the destruction of the controller, in which case we cannot assume any warranty.

Terminal Assignment

Terminal number	Max. terminal range	Assignment	Notes
1 2	2,5 mm ²	Supply voltage Supply voltage	230 V AC 50/60 Hz or as specified on unit housing
3 4 5	2,5 mm ²	Relay, normally-closed Relay, input Relay, normally-open	Alarm output or switching output, motor opening
6 7	2,5 mm ²	Relay, input Relay, normally-open	pwm switching output or switching output, motor closing
8 9	1,5 mm ²	Transmitter supply + Transmitter supply -	18 V DC / 25mA
10 11 12 13	1,5 mm ²	GND, signal- 0-20mA, 4-20mA, signal+ 0-1V, singal+ 0-10V, signal+	signal input
14 15	1,5 mm ²	Connection B Connection A	RS485
16 17	1,5 mm ²	Analog output + Analog output -	only for units with optional analog output

Assignment Diagram

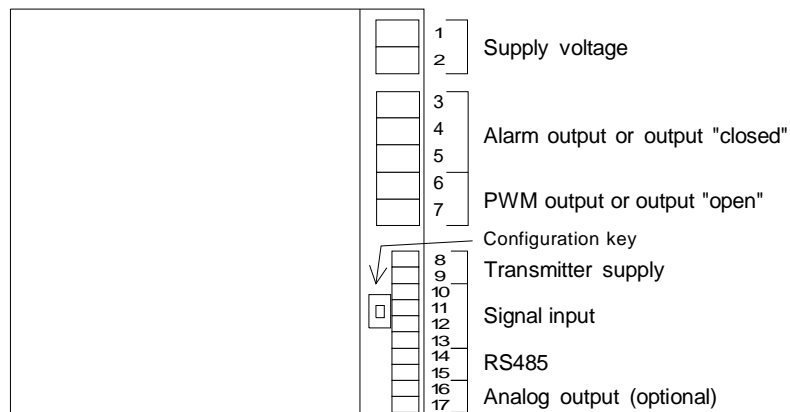

GIR1002NS (plan view)

Transmitter Connection

Connection of a 4 to 20 mA transmitter in 2-wire technologie

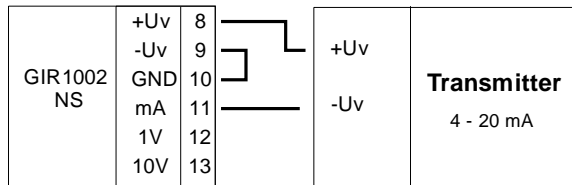

Connection of a 0(4) to 20 mA, 0 to 1 V, 0 to 10V transmitters in 3-wire technologie

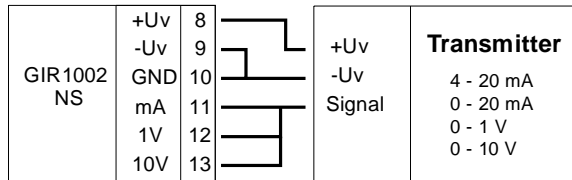

Connection of a 0(4) to 20 mA, 0 to 1 V, 0 to 10V transmitters in 4-wire technologie

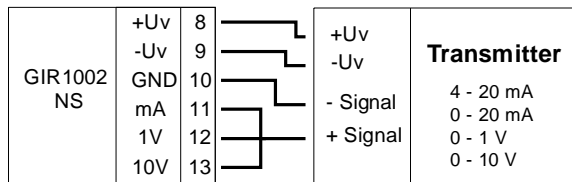

Technical Specifications

Sensor input:	0 to 20mA, 4 to 20mA, 0 to 1Volt, 0 to 10Volt	Ri=50 Ohm Ri=50 Ohm Ri=30 kOhm Ri=300 kOhm
Output voltage for sensors:	18Volt DC / 25mA, electrically isolated	
Display range:	lowest and highest value to be selected individually	
Max. display value:	9999 digit	
Min. display value:	-1999 digit	
Decimal point :	position to be selected individually	
Measuring accuracy:	0.1% ± 1 Digit	
Control function:	PID controller with PWM output and min./max. alarm PD/PI controller with PWM output and min./max. alarm Adjuster controller	
Analog output: [optional]	4-20mA resp. 0-10V, scale to be selected individually	
Alarm delay: [optional]	0 - 99 min, selectable	
Interface:	RS485	
Nominal temperature:	25° C	
Ambient temperature:	0 to 50° C	
Atmospheric humidity:	0 to 80% (not condensing)	
Power supply:	230VAC or as specified on device housing	
Power consumption	5W (230VAC), 3W (24VDC), 1,5W (12VDC)	
Relay switching power:	10A, 250V AC (ohmic load) use RC-element when switching inductive loads	
Electromagnetic compatibility:	In accordance with EN50081-1 and EN50082-2 for unrestricted use in housing and industrial areas additional error: <1%	
Housing:	standard rack housing, 48 x 96 x 100 mm (H x W x D)	
Control panel cutout:	43 x 90.5 mm (H x W)	
Connecting terminal:	screw-type/plug-in terminals	

Operation

Start-up

As soon as the supply voltage has been applied the GIR1002 NS-S/T will carry out a segment test for approx. 8s. Then the current measuring value will be displayed.

Table of Functions

The various functions are called up/input by means of the 4 buttons located at the front side of the device. We would like to point out that depending on the output configuration (also refer to chapter 'configuration') only a certain number of functions will be available.

The following table shows all the functions of the GIR1002 NS-S/T. The right hand column indicates the controller configuration for the various functions.

Functions	To be called up by	Output configuration
display of current measuring value:	briefly pressing button 4	0 .. 2
alarm reset:	pressing button 4 for 4 s	0,1
display of max. value:	briefly pressing button 2	0 .. 2
max. value reset:	pressing button 2 for 4 s	0 .. 2
display of min. value:	briefly pressing button 3	0 .. 2
min. value reset:	pressing button 3 for 4 s	0 .. 2
display/setting of switching point (set-point value):	button 1 .. 4	0 .. 2
display/setting of proportional band (Xp):	button 1 .. 4	0 .. 2
display/setting of integral time (Tn):	button 1 .. 4	0,1
display/setting of derivative time (Tv):	button 1 .. 4	0 .. 2
display/setting of cycle time (T):	button 1 .. 4	0 .. 2
display/setting of max. alarm limit:	button 1 .. 4	0,1
display/setting of min. alarm limit:	button 1 .. 4	0,1
display/setting of alarm delay:	button 1 .. 4	optional (0,1)

Display of current measuring value

To be called up by:	briefly pressing button 4
Display:	the current measuring value is shown on the 7-segment display
LED "1":	gives status of relay 1
LED "2":	gives status of relay 2
	LED flashing: relay contact made
	LED not flashing: relay contact broken
LED "ALARM":	LED flashing in case of alarm.
LED "min":	LED flashing in case of MIN alarm.
LED "max.":	LED flashing in case of MAX alarm.

Alarm reset

To be called up by:	pressing button 4 for approx. 4s
Display:	please refer to "display of current measuring value"

Display of max. value

To be called up by:	briefly pressing button 2
Display:	The 7-segment display shows the max. value
LED "1":	gives status of relay 1
LED "2":	gives status of relay 2
	LED flashing: relay contact made
	LED not flashing: relay contact broken
LED "ALARM":	LED flashing in case of alarm.
LED "max.":	LED flashing

Max. value reset

To be called up by: pressing button 2 for approx. 4s
 Display: please refer to "display of max. value"

Display of min. value

To be called up by: briefly pressing button 3
 Display: The 7-segment display shows the min. value
 LED "1": gives status of relay 1
 LED "2": gives status of relay 2
 LED flashing: relay contact made
 LED not flashing: relay contact broken
 LED "ALARM": LED flashing in case of alarm.
 LED "min.": LED flashing

Min. value reset

To be called up by: pressing button 3 for approx. 4s
 Display: please refer to "display of min. value"

Display / setting of switching point (set point value)

To be called up by: pressing button 1 till LEDs "SET", "1" and "ON/SP" are illuminated.
 Display: The 7-segment display shows the switching point.
 Setting: Set switching point by means of buttons 2 and 3. LED "1" and "ON/SP" will start flashing.
Buttons 2 and 3 are equipped with a scrolling function, i.e. the switching point will be increased respectively decreased by 1 digit when button 2 respectively button 3 is pressed briefly (no more than 1 s). When pressing these buttons for a longer time (over 1 s) the values will start "scrolling" upwards respectively downwards. After "scrolling" of approx. 150 digits the "scrolling speed" will be increased by a factor of 10.
 Use button 4 to acknowledge new switching point.
 LEDs "1" and "ON/SP" will stop flashing.
 Switch over to display of current measuring value by pressing button 4 once again.

Display / setting of proportional band (Xp)

To be called up by: pressing button 1 till LEDs "SET", "1" and "OFF/Hy." are illuminated.
 Display: The 7-segment display shows the proportional band.
 Setting: Set proportional band by means of buttons 2 and 3. LEDs "1" and "OFF/Hy." will start flashing.
 Use button 4 to acknowledge new switching point.
 LEDs "1" and "OFF/Hy." will stop flashing.
 Switch over to display of current measuring value by pressing button 4 once again.

Display / setting of integral time (Tn)

To be called up by: pressing button 1 till LEDs "SET", "T" and "ON/Sp." are illuminated.
 Display: The 7-segment display shows the integral time.
 Setting: Set integral time by means of buttons 2 and 3.
 LEDs "T" and "ON/Sp." will start flashing.
 Use button 4 to acknowledge new switching point.
 LEDs "T" and "ON/Sp." will stop flashing.
 Switch over to display of current measuring value by pressing button 4 once again.
Important advice: When using the device as signal actuating controller (out.2) the reset time "Tn" has to be 0 ! (refer to Page 10)

Display / setting of derivative time (Tv)

- To be called up by: pressing button 1 till LEDs "SET", "T" and "OFF/Hy." are illuminated.
- Display: The 7-segment display shows the derivative time.
- Setting: Set derivative time by means of buttons 2 and 3.
LEDs "T" and "OFF/Hy." will start flashing.
Use button 4 to acknowledge new derivative time.
LEDs "T" and "OFF/Hy." will stop flashing.
Switch over to display of current measuring value by pressing button 4 once again.

Display / setting of cycle time (T)

- To be called up by: pressing button 1 till LEDs "SET", and "T" are illuminated.
- Display: The 7-segment display shows the cycle time.
- Setting: Set cycle time by means of buttons 2 and 3. LED "T" will start flashing.
Use button 4 to acknowledge new cycle time.
LED "T" will stop flashing.
Switch over to display of current measuring value by pressing button 4 once again.

Display / setting of max. alarm limit

- To be called up by: pressing button 1 till LEDs "SET", "ALARM" and "max." are illuminated.
- Display: The 7-segment display shows the max. alarm limit.
- Setting: Set max. alarm limit by means of buttons 2 and 3.
LEDs "ALARM" and "max." will start flashing.
Use button 4 to acknowledge new max. alarm limit
LEDs "ALARM" and "max." will stop flashing.
Switch over to display of current measuring value by pressing button 4 once again.

Display / setting of min. alarm limit

- To be called up by: pressing button 1 till LEDs "SET", "ALARM" and "min." are illuminated.
- Display: The 7-segment display shows the min. alarm limit.
- Setting: Set min. alarm limit by means of buttons 2 and 3. LEDs "ALARM" and "min." will start flashing.
Use button 4 to acknowledge new min. alarm limit.
LEDs "ALARM" and "min." will stop flashing.
Switch over to display of current measuring value by pressing button 4 once again.

Display/setting of alarm delay [optional]

- To be called up by: Push the button at the rear of the GIR1002 till the LED "SET" is illuminated. Pressing button 1 till LEDs "SET", "ALARM" are illuminated.
- Display: The 7-segment display shows "d." and the alarm delay.
- Setting: Set alarm delay by means of buttons 2 and 3.
Use button 4 to acknowledge new min. alarm limit.
Switch over to display of current measuring value by pressing button 4 once again.

Configuration

1) Press button 1 (front side).

Press miniature push button on the back side of the GIR1002 NS-S/T (located behind the sensor connection terminal) **in addition** (for approx. 1 s) till LED "CAL" (on front side) is flashing.

2) LED "CAL" is illuminated.

The display will show "InP.0", "InP.1", "InP.2" or "InP.3".

Use buttons 2 and 3 to select input signal desired (point will start flashing).

"InP.0" =	0 - 20mA
"InP.1" =	4 - 20mA
"InP.2" =	0 - 1 Volt
"InP.3" =	0 - 10 Volt

Acknowledge input signal selected by pressing button 4.

3) LED "CAL" is illuminated.

The display will show four dashes as well as the decimal point on the position where they are stored. Use button 2 (shift decimal point to the left) or button 3 (shift decimal point to the right) to set desired decimal point position; acknowledge position by pressing button 4.

If decimal point is positioned to the right of the lowest digit position displayed, this means that no decimal point will be shown as soon as the controller is back in the control mode.

4) LEDs "Scale", "max." and LED "CAL" are illuminated.

The display will show the upper limit of the measuring range (value displayed at 20mA, 1V respectively 10V input signal) stored in the GIR1002 NS-S/T.

Use buttons 2 and 3 to set new upper limit of the measuring range (LED "max." will start flashing); acknowledge by pressing button 4.

Buttons 2 and 3 are equipped with a scrolling function, i.e. the value will be increased respectively decreased by 1 digit when button 2 respectively button 3 is pressed briefly (no more than 1 s). When pressing these buttons for a longer time (over 1 s) the values will start "scrolling" upwards respectively downwards. After "scrolling" of approx. 150 digits the "scrolling speed" will be increased by a factor of 10.

5) LEDs "Scale", "min." and LED "CAL" are illuminated

The display will show the lower limit of the measuring range (value displayed at 0mA, 4 mA respectively 0V input signal) stored in the GIR1002 NS-S/T.

Use buttons 2 and 3 to set new lower limit of the measuring range (LED "min." will start flashing); acknowledge by pressing button 4.

6) LED "CAL" is illuminated.

The display will show "FIL.0", "FIL.1", "FIL.2" or "FIL.3".

Use buttons 2 and 3 to select filter desired (point will start flashing).

"FIL.0"	no filter
"FIL.1",	filter 1 active
"FIL.2"	filter 2 active
"FIL.3"	filter 1 and filter 2 active

Filter1: for filtering short pikes occurring when relays and contactors are switched. Make sure to activate filter 1 always, if high loads are switched in the vicinity of the controller, wires or sensor or if large pikes are to be expected.

Additional display delay: approx. 0.5s

Filter 2: prevents "jumping" of the last figure, a phenomenon often found with digital displays and controllers. Make sure to always activate filter 2 if the display range exceeds 2000 digits.

Additional display delay: approx. 1s

Acknowledge filter selected by pressing button 4

7) LED "CAL" is illuminated.

The display shows the letter combination "nr." followed by the interface address set (0 .. 15).
Use buttons 2 and 3 to set new interface address (point will start flashing) and acknowledge by pressing button 4.
If the RS485 interface is not used, this setting will not have any meaning (please also refer to description of interface).

8) LEDs "Analog", "max." and LED "CAL" are illuminated.

The display will show the measuring value stored in the GIR1002 NS-S/T for which a 20mA signal will be given at the analog output.

(This function is only available for devices equipped with the option "analog output".)

Use buttons 2 and 3 to set new display value for an output current of 20mA (LED "max." will start flashing); acknowledge by pressing button 4.

9) LEDs "Analog", "min." and LED "CAL" are illuminated.

The display will show the measuring value stored in the GIR1002 NS-S/T for which a 4mA signal will be given at the analog output.

(This function is only available for devices equipped with the option "analog output".)

Use buttons 2 and 3 to set new display value for an output current of 4mA (LED "min." will start flashing); acknowledge by pressing button 4.

10) LED "CAL" is illuminated.

The display shows the letter combination "out." followed by the controller type set (0 .. 2).

Use buttons 2 and 3 to set desired controller type (point will start flashing).

"out.0":	PID controller with PWM output and min./max. alarm
"out.1":	PD/PI controller with PWM output and min./max. alarm
"out.2":	Signal actuating controller (take notice of the remark about "Reset time Tn")

Acknowledge controller type selected by pressing button 4.

The display will show the current measuring value again.

The configuration of the GIR1002 NS-S/T has now been completed.

Steps 1 to 10 can be repeated any number of times to either correct a setting error or to input a new setting.

Unless a button is pressed at least approx. every 2 minutes during the setting process, the GIR1002 NS-S/T will stop the setting process. Then, "CAL" will stop flashing. In such a case we recommend to repeat the setting process.

Important note for controller type "signal actuating controller" (out.2):

When using the device as signal actuating controller (out.2) the reset time "Tn" has to be 0.

This value is default factory setting.

Please consider, that the reset time Tn can only be set in PID-mode (out.0) or PD/PI-mode (out.1).

Fault Codes

In case of unacceptable conditions in the system a fault code will be displayed.

Fault codes have been defined as follows:

FE 1: Measuring range has been exceeded

This fault code indicates that the measuring range of the A/D converter has been exceeded.

Potential fault cause: transmitter damaged
short-circuit in transmitter connection

Remedies: FE 1 will be reset as soon as the measuring values are back within their permissible range. Please check your transmitter and transmitter connecting cables.

FE 2: Measuring values have fallen below permissible range

This fault code indicates that the measuring values of the A/D converter have fallen below the permissible range.

Potential fault cause: transmitter damaged
transmitter connection interrupted

Remedies: FE 2 will be reset as soon as the measuring values are back within their permissible range. Please check your transmitter and transmitter connecting cables.

FE 3: Display range has been exceeded

This fault code indicates that the max. display value of 9999 digits has been exceeded.

Remedies: FE 3 will be reset as soon as the measuring values are back within their permissible range.

FE 4: Values on the display have fallen below permissible range

This fault code indicates that the measuring values of the A/D converter have fallen below the permissible range.

Remedies: FE 4 will be reset as soon as the values on the display are back within their permissible range.

RS485 interface

The serial interface of the GIR1002 NS-S/T allows communication of the device with a host computer. Data polling and transfer is done in the master/slave mode, i.e. the GIR1002 NS-S/T will only transmit data upon request. A separate device address can be attributed to each GIR1002 NS-S/T. Addresses 0 to 15 are implemented. The GIR1002 NS-S/T will respond when requested to do so by the host, provided the device number of the request string corresponds to the one set (response of GIR1002 NS-S/T 20 to 60ms after request has been completed). This method as well as the fact that the interface operates in the half-duplex mode ensure that up to 16 devices can be called via only one 2-wire line.

Interface configuration

Type	RS485
Transfer mode	half-duplex
Connection	2-pin screw/plug-in connection
Connecting cable	2-pin, twisted.

Data transfer format:

2400 Baud
1 start bit
7 data bits
no parity bit
1 stop bit

Communication is entirely achieved by means of printable ASCII code.

Data transfer processing protocol

Request data from GIR1002 NS-S/T

Request string to GIR1002 NS-S/T

	!	Nr.	Nr.	F1	F2	/
Byte	1	2	3	4	5	6

Response from GIR1002 NS-S/T

	#	F1	F2	\$	D1	D2	D3	D4	/
Byte	1	2	3	4	5	6	7	8	9

Send data to GIR1002 NS:

Send string to GIR1002 NS-S/T

	!	Nr.	Nr.	#	F1	F2	\$	D1	D2	D3	D4	/
Byte	1	2	3	4	5	6	7	8	9	10	11	12

Response from GIR1002 NS-S/T

	#	a	/	if data have been successfully taken over
Byte	1	2	3	

Description of characters used:

- ! : ASCII-Code: 21H
This character interrupts a connection, if any is existing, and resets all GIR1002 NS-S/T devices connected to their original state thus initialising a check to ensure that the following two characters correspond to their respective device numbers.
- Nr.: Permissible range "0" to "9" and "A" to "F"
(corresponding to ASCII code 30H to 39H and 41H to 46H)
As a precaution device number will be transmitted twice.
Data will not be processed by the GIR1002 NS-S/T unless the device number transmitted is identical to the one set in the respective GIR1002 NS-S/T. If numbers are not identical the device will only check if the data stream contains another "!" character thus indicating a new data circuit.
- F1,F2: Permissible range see table 1
Functional codes, specifying the parameter and/or value to be processed. For assignments please refer to table 1 of chapter 'functional code'.
- /: ASCII-Code: 2FH
Indicates the end of a data transfer process. Each data transfer process, either from host to GIR1002 NS-S/T or from GIR1002 NS-S/T to host is completed by putting "/".
- # : ASCII-Code: 23H
Indicates the beginning of a data transfer process.
'#' is issued by the GIR1002 NS-S/T prior to starting transfer of data to the host. If the character '#' is transferred by the host after issuing of the device number, the GIR1002 NS-S/T will know that data are to be transferred from the host to the GIR1002 NS-S/T (programming of GIR1002 NS-S/T).
- \$: ASCII-Code: 24H
Signals that the data following will be transferred in hexadecimal code.
- D1..D4: Permissible range '0' to '9' and 'A' to 'F'.
(corresponding to ASCII code 30H to 39H and 41H to 46H)
Data will be presented in the hexadecimal mode. For more detailed information please refer to chapter 'Data formats'.
- a : ASCII-Code: 61H
Transferred as hand-shake signal by the GIR1002 NS after successful data input to the memory.
-

Functional code

The value (parameter) to be read respectively re-programmed is specified by two bytes, designed F1 and F2 in the data transfer protocol.

Table 1 illustrates the assignment of functional code and value (parameter) as well as of the valid data format.

It is vital to ensure that only those functional codes and their permissible data as stated in table 1 are transmitted to the GIR1002 NS-S/T as otherwise internal settings of the device could be changed.

Parameter resp. value	ASCII character		ASCII code		Data format
	F1	F2	F1	F2	
Display value	0	0	30H	30H	1
Max. value	0	1	30H	31H	1
Min. value	0	2	30H	32H	1
System state	0	3	30H	33H	2
Switching point (set point value)	0	4	30H	34H	1
Proportional band (Xp)	0	5	30H	35H	7
Integral time (Tn)	0	6	30H	36H	8
Derivative time (Tv)	0	7	30H	37H	9
Cycle time (T)	0	8	30H	38H	10
Max. alarm limit	0	B	30H	42H	1
Min. alarm limit	0	C	30H	43H	1
Input signal	1	5	31H	35H	3
Position of decimal point	0	E	30H	45H	4
Display value for 20mA, 1V or 10V	0	F	30H	46H	1
Display value for 0mA or 0V	1	0	31H	30H	1
Filter	1	1	31H	31H	5
Display value for 20mA signal of the analog output	1	3	31H	33H	1
Display value for 4mA signal of the analog output	1	4	31H	34H	1
Interface adresse	1	2	31H	32H	6

table 1

Dataformat

General information

The four bytes termed D1 to D4 in the data transfer protocol represent the parameter value specified by F1 and F2.

The value is represented in hexadecimal printable ASCII characters.

The GIR1002 NS-S/T treats all values as 16 bit words, which means that a range of values from -32768 to +32767 and correspondingly a range from 8000H to 7FFFH can be displayed.

The following 4 data bytes contain the 16 bits mentioned above:

D1	equalising	Bit	15	to	12
D2	equalising	Bit	11	to	8
D3	equalising	Bit	7	to	4
D4	equalising	Bit	3	to	0

Examples:

Value		ASCII-character				ASCII-code			
dezimal	hex	D1	D2	D3	D4	D1	D2	D3	D4
0	0000H	0	0	0	0	30H	30H	30H	30H
-1	FFFFH	F	F	F	F	46H	46H	46H	46H
-1999	F831H	F	8	3	1	46H	38H	33H	31H
9999	270FH	2	7	0	F	32H	37H	30H	46H

Data format 1:

Data format 1 corresponds to the general data format. It is only the range of values that is limited to the display range of -1999 to +9999 equalising F831H to 270FH.

The decimal point will not be considered. The decimal point position can be called up separately.

Data format 2:

This format is used to call up and reset the system state. Data bytes D1 to D4 contain information regarding the alarm and fault state of the GIR1002 NS-S/T.

The assignment is as follows:

Data byte D2:	Bit 0 = 1:	Fault FE1 active
	Bit 1 = 1:	Fault FE2 active
	Bit 2 = 1:	Fault FE3 active
	Bit 3 = 1:	Fault FE4 active
Data byte D4:	Bit 0 = 1:	max. alarm
	Bit 1 = 1:	min. alarm
	Bit 3 = 1:	alarm

Data format 3:

This format is used to call up and program the input signal.

The assignment is as follows:

0 :	Current input 0 to 20 mA
1 :	Current input 4 to 20mA
2 :	Voltage input 0 to 1 Volt
3 :	Voltage input 0 to 10 Volt

Data format 4:

This format is used to call up and/or program the position of the decimal point.

The assignment is as follows:

0 :	no decimal point
1 :	decimal point after 2 digits (10)
2 :	decimal point after 3 digits (100)
3 :	decimal point after 4 digits (1000)

Data format 5:

This format is used to call up and program the filter.

The assignment is as follows:

- 0 : filter off (FILt = 0)
- 1 : filter 1 on (FILt = 1)
- 2 : filter 2 on (FILt = 2)
- 3 : filter 1 and filter 2 on (FILt = 3)

Data format 6:

This format is used to program the device address. Permissible device addresses range from 0 to 15.

Data format 6 corresponds to the general data format. It is only the range of values that is limited to the permissible device addresses 0 to 15, respectively 0000H to 000FH.

Data format 7:

Data format 7 corresponds to the general data format. It is only the range of values that is limited to the proportional band of -1500 to +1500 digit equalising FA24H to 05DCH.

The decimal point will not be considered. The decimal point position can be called up separately.

Data format 8:

Data format 8 corresponds to the general data format. It is only the range of values that is limited to the integral time of 0 to 1800 seconds equalising 0H to 0708H.

Data format 9:

Data format 9 corresponds to the general data format. It is only the range of values that is limited to the derivative time of 0 to 200 seconds equalising 0H to 00C8H.

Data format 10:

Data format 10 corresponds to the general data format. It is only the range of values that is limited to the cycle time of 0 to 900 seconds equalising 0H to 0384H.

Annex A: Practical advice for setting the GIR1002 NS-S/T when using it as heating controller

1. Set-point value SP

The set-point SP indicates the temperature which is to be controlled by the GIR1002. Use this value to set desired temperature.

2. Proportional range Xp

The proportional range Xp determines the reaction of the GIR1002 if the nominal temperature deviates from the set-point temperature. If the deviation is identical to the proportional range Xp the heating power is 100%. If the deviation is 0° C the heating power is 0%.

Example 1: Sp=200.0, Xp=50.0

Nominal temperature=150°C → deviation=50°C → heating power=100%

Nominal temperature=180°C → deviation=20°C → heating power=40%

Example 2: Sp=200.0, Xp=100.0

Nominal temperature=150°C → deviation=50°C → heating power=50%

Nominal temperature=180°C → deviation=20°C → heating power=20%

A small proportional range makes the GIR1002 device react with a large change in the heating power even if the set-point deviation is only small.

If the proportional range set is too small this may lead to an 'overreaction', the control is no longer stable.

!! Attention: If Xp is too small this may lead to considerable over-temperatures !!

If the proportional range is too large, the controller does not react sufficiently to changes, the control is too passive.

How to determine the optimum proportional range Xp:

Set the following values at your GIR1002 device:

Set-point value SP:	desired temperature
Proportional range Xp:	150.0
Reset time Tn:	0 (off)
Set time Tv:	0 (off)
Cycle time T:	2s (10s for a passive control circuit)

Tn and Tv will be set to off. The GIR1002 works as a P-controller.

Start up controller and wait for a constant temperature. This temperature, which is much below the set-point value, should be stable. Then, reduce Xp so that the deviation from the set-point value is also reduced. Reduce Xp till the temperature is no longer stable but continues to fluctuate (approx. ±1°C). If the fluctuation is too large, increase Xp slightly.

Please note that you may have to consider a very long response time depending on the control circuit.

To finally set Xp use twice the value determined.

3. Reset time Tn

Under point 2 the GIR1002 was configured solely as a P-controller, which does not react but to the deviation of the nominal temperature from the set-point temperature. As the heating is completely off if the deviation is 0, the controlled temperature will always be below the set-point value. This is not the case for a PI-controller, which also acts as an integral controller. This means, that not only the deviations will be considered but also the period of time this deviation exists. The longer the deviation exists, the stronger the heating power. The heating power changes as long as there is a deviation so that even smaller deviations can be compensated for after a certain time.

The reset time Tn determines the reaction. If Tn is small, the GIR1002 quickly moves to the set-point temperature.

If Tn is too small, the effect is an 'overshoot'. The control circuit is no longer stable, the temperature fluctuates round the set-point value.

!! Attention: If Tn is too small this may lead to considerable over-temperatures !!

If Tn is too large, it may, however, take a very long time till the set-point value is reached.

How to determine the reset time T_n

Set the following values at your GIR1002 device:

Set-point value SP:	desired temperature
Proportional range X_p :	as determined under 2
Reset time T_n :	3600
Set time T_v :	0 (off)
Cycle time T:	2s (10s for a passive control circuit)

T_v will be set to off. The GIR1002 works as a PI-controller.

Start up controller and wait for the set-point value to be reached. If this takes too long, reduce T_n . To avoid unwanted overshoot, we ask you to monitor the speed of the temperature rise. If the increase is only low, reduce T_n even further. If the increase is considerable, please increase T_n as well. Unless T_n is already too small the temperature should be stable at the set-point value. An interference will be introduced to the control circuit (e.g. filling cold water into a water basin or placing a cold object on a temperature controlled metal bloc, etc.); if possible the interference should be similar to an interference that may actually arise under operating conditions. If an interference can be produced the set-point value can be changed. Please watch the GIR1002 return to the set-point temperature. If there is a temperature overshoot, the reset time T_n has to be increased. If the set-point temperature is reached only slowly, the reset time T_n can even be reduced.

Please note that you will have to wait for the response time to be completed (several minutes depending on control circuit) after each T_n change.

Increase T_n by 1.2 of the value determined.

4. Set time T_v

If cold water is poured into a basin with hot water the temperature in the basin will drop rapidly. If the temperature in the basin is controlled manually, the operator will intuitively add a lot of heating power, then reduce it again to finally reach the set-point temperature by slowly changing the heating power.

It is the D-part (differential part) of the PID-controller that takes over this task of quickly reacting to large temperature changes. The D-part does not react to the deviation of the temperature from the set-point value but to the actual temperature change. If the temperature drops quickly, the D-part ensures a high heating power. If the set-point temperature is reached very quickly the D-part reduces the heating power pre-determined by the P and I-parts. If there is no temperature change the D-part is 0.

The reaction caused by the D-part is determined by the set time T_v . A small T_v induces only a small reaction to temperature changes, a high T_v causes a strong reaction.

In many applications a PI-controller is sufficient; in such cases set the T_v time of the GIR1002 to 0.

If a PID-controller is required the T_v has to be determined. To do so you need to have an exact knowledge of your control distance as well as some basic knowledge about controlling. Our experience has shown that in most cases a set time $T_v = T_n/5$ can be used.

Set T_v to 0.2 of the T_n value.

5. Cycle time T

The GIR1002 NS-S/T (T-type) controls the heating power by switching on/off the existing heating. If only 50% of the existing heating power are required the heating will only be switched on for half the time. The cycle time T determines the frequency of switching on/off.

Example: existing heating power 1000 W, required heating power 600 W

If cycle time is $T=10s$ the GIR1002 will switch the heating on for 6s and off for 4s.

If cycle time was $T=200s$ the heating would be on for 120s and off for 80s.

If too large a cycle time is selected the object to be heated will get too hot during the long time the heater is switched on (although the settings for X_p , T_n and T_v are correct), only to cool down during the time the device is switched off. Too small a cycle time results in frequent switching operations of the relays, which, in the long run, will reduce their service life. An optimum cycle time does not create any obvious effect during the time the device is switched on/off.

How to determine cycle time T:

Increase cycle time till just before the point where the control effect will start to deteriorate.

Set T to 0.8 of this value.