



Mounting and Operating Manual

96x48 Panel Mount Display / Controller

as of version 3.1

GIA 2000 / GIR 2002



-  Please read these instructions carefully before use!
-  Please consider the safety instructions!
-  Please keep for future reference!



WEEE-Reg.-Nr. DE 93889386

Contents

1. SAFETY	3
1.1. General note	3
1.2. Intended use	3
1.3. Skilled personnel.....	3
1.4. Type label	4
1.5. Safety signs and symbols	4
1.6. Reasonably foreseeable misuse.....	5
1.7. Safety guidelines	5
2. PRODUCT DESCRIPTION.....	5
2.1. Scope of supply	5
2.2. Function	6
3. MOUNTING IN PANELS / HOUSINGS.....	7
4. DISPLAY AND OPERATING ELEMENTS.....	7
4.1. Display elements	7
4.2. Operating elements	8
5. ELECTRIC CONNECTION.....	8
5.1. Terminal assignment: Standard.....	9
5.2. Terminal assignment for options.....	9
5.3. Connection data	11
5.4. Connecting an input signal.....	12
5.5. Connecting switching outputs (only for GIR 2002).....	15
5.6. Common wiring of several devices.....	15
6. CONFIGURATION OF THE MEASURING INPUT	16
6.1. Selecting an input signal type	16
6.2. Measuring temperature (Pt100, Pt1000 RTD probes and thermocouple type J, K, N, S or T).....	17
6.3. Measuring voltage and current (0-50mV, 0-1V, 0-2V, 0-10V, 0-20mA, 4-20mA).....	18
6.4. Measuring of frequency (TTL, switching-contact).....	19
6.5. Measuring of flow rate (TTL, switching-contact).....	20
6.6. Measuring of rotation speed (TTL, switching-contact)	21
6.7. Up-/Downwards counter (TTL, switching-contact).....	22
6.8. Interface mode	23
7. CONFIGURATION OF THE ANALOG OUTPUT (ONLY WITH OPTION AAG).....	24
7.1. Scaling the analog output.....	24
8. CONFIGURATION OF THE OUTPUT FUNCTIONS (ONLY FOR GIR 2002).....	25
8.1. Selection of the output function.....	25
8.2. 2-point-controller, 3-point-controller.....	26
8.3. 2-point-controller with alarm function, 3-point-controller with alarm function.....	27
8.4. Min-/Max-Alarm (individual or common)	28
9. OFFSET- AND SLOPE-ADJUSTMENT.....	29
9.1. Menu calling and adjustment	30
10. SWITCHING POINTS AND ALARM-BOUNDARIES (ONLY FOR GIR 2002)	31
10.1. Menu calling	31
10.2. 2-point-controller, 3-point-controller.....	32
10.3. 2-point-controller with alarm function, 3-point-controller with alarm function.....	32
10.4. Minimum/maximum-alarm (individual or common).....	33
11. MIN-/MAX-VALUE MEMORY:	34
12. SERIAL INTERFACE.....	34
13. ALARM DISPLAY (ONLY GIR 2002).....	34
14. ERROR CODES	35
15. SPECIAL FUNCTIONS (OPTIONALLY): TARE	36
16. DECOMMISSIONING, RESHIPMENT AND DISPOSAL.....	36
16.1. Decommissioning	36
16.2. Reshipment and disposal.....	36

17. SPECIFICATION 37**1. Safety****1.1. General note**

Read this document carefully and get used to the operation of the device before you use it. Keep this document within easy reach near the device for consulting in case of doubt.

Mounting, start-up, operating, maintenance and removing from operation must be done by qualified, specially trained staff that have carefully read and understood this manual before starting any work.

The manufacturer will assume no liability or warranty in case of usage for other purpose than the intended one, ignoring advices of this manual, operating by unqualified staff as well as unauthorized modifications to the device.

1.2. Intended use

The GIA 2000 is a universal microcontroller based display unit.

The GIR 2002 has additional relay outputs and therefore is also applicable for monitoring and controlling purposes.

The devices are only to be operated in control panels or suitable electric housings, where the connection terminal area is sufficiently protected against touch.

They are designed for industrial or commercial use.

Outdoor installation without suitable means of protection is not allowed.

Due to the flexibly configurable universal input and the relay outputs of the GIR 2002 they are applicable for many different applications.

The relay outputs are suitable to switch electrical loads with max 5 A (output 1) or 10 A (output 2) resistive load at up to 250 V AC.

Prior to fulfil the referring requirements, the device has to be configured on the base of this manual. Wrong configuration may lead to malfunction in the application. The commissioning expert / the operator is liable for a suitable configuration.

The counting function is not to be used for e.g. consumption metering in the sense of the measuring instruments directive 2014/32/EU.

The safety guidelines of the manual are followed!

The unit does not contain any components that you can service or repair yourself.

All the described operations are only to be performed of skilled personnel that are authorized by the operator.

Any other use or use exceeding this is considered as non-conforming and leads to the expiration of any liability or guarantee claims from the manufacturer.

Note: Combination / connection to other electrical equipment with CE marking does not automatically deliver a conform system. A new evaluation of the system's conformity to the low voltage directive (2014/35/EU) and EMC directive (2014/30/EU) by the manufacturer may be necessary, eventually others have to be considered (e.g. machinery directive).

1.3. Skilled personnel

The mounting, electrical installation, start of operation, maintenance and decommissioning must only performed by a skilled electrician.

Users of the readily installed device have to be sufficiently skilled in the operation of the device and able to avoid risks. The operator of the arrangement is responsible for sufficient qualification the operators.

1.4. Type label

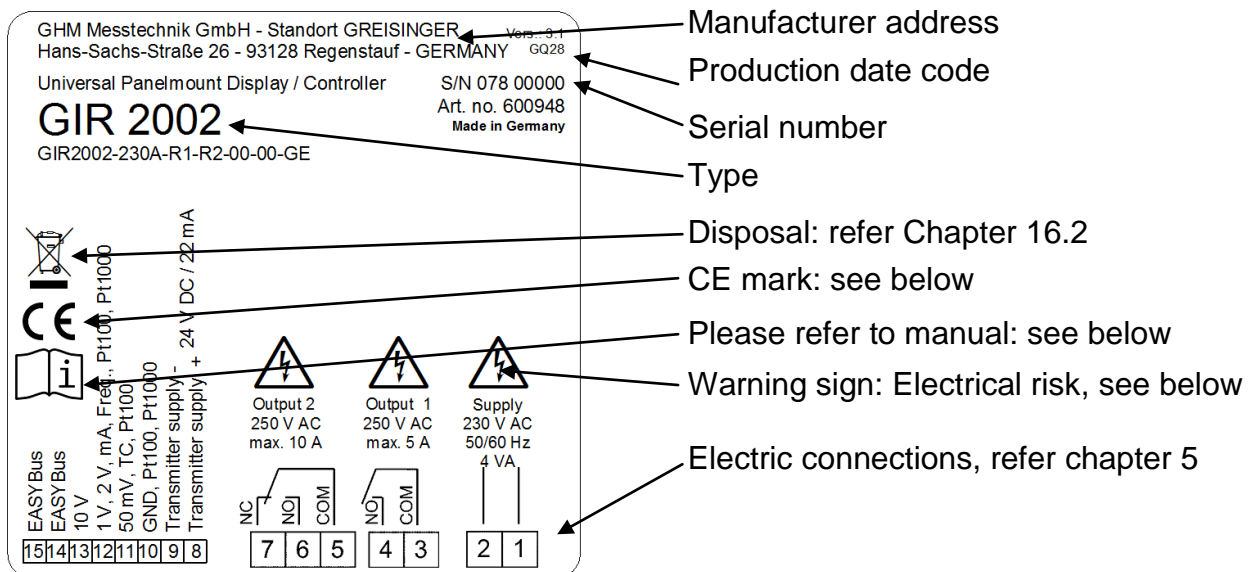

Symbol explanation



Electrical risk:

At electrical connections and components signed with this symbol there is a risk of electrical shock.



Please refer to manual:

Read the mounting- and operating manual carefully, before you connect and use the device.



CE mark:

With the CE-Sign declares the manufacturer, that the Product is conform with the prevailing requirements of EG.

1.5. Safety signs and symbols

Warnings are labelled in this document with the followings signs:



Caution!

This symbol warns of imminent danger, death, serious injuries and significant damage to property at non-observance.



Attention!

This symbol warns of possible dangers or dangerous situations which can provoke damage to the device or environment at non-observance.



Note!

This symbol point out processes which can indirectly influence operation, possibly cause incorrect measurement or provoke unforeseen reactions at non-observance.

1.6. Reasonably foreseeable misuse

- 
DANGER

This device must not be used at potentially explosive areas!
Do not use these products as safety or emergency stop devices or in any other application where failure of the product could result in personal injury or material damage.
Failure to comply with these instructions could result in death or serious injury and material damage.
- 
ATTENTION

This device must not be used at a patient for diagnostic or other medical purpose.

1.7. Safety guidelines

- Faultless operation and reliability in operation of the measuring device can only be assured if the device is used within the climatic conditions specified in the chapter "Specifications".
- Always disconnect the device from its supply before opening it. Take care that nobody can touch any of the unit's contacts after installing the device.
- Standard regulations for operation and safety for electrical, light and heavy current equipment have to be observed, with particular attention paid to the national safety regulations (e.g. VDE 0100).
- When connecting the device to other devices (e.g. the PC) the interconnection has to be designed most thoroughly, as internal connections in third-party devices (e.g. connection of ground with protective earth) may lead to undesired voltage potentials.
- 
DANGER

The device must be switched off and must be marked against using again, in case of obvious malfunctions of the device which are e.g.:

 - Visible damage.
 - Device does not work like prescribed.
 - Storing the device under inappropriate conditions for longer time.

When not sure, the device should be sent to the manufacturer for repairing or servicing.
- Modifications or repairs of the device may not be performed by the customer. For maintenance or repair the device must be sent to the manufacturer.
- 
ATTENTION

If the device is operated at an ambient temperature > 40 °C the connections may heat up above 60 °C.
Please keep this in mind when electing suitable connection cables.

2. Product description

2.1. Scope of supply

The scope of supply includes:

- monitoring- / controlling device
- 2 mounting brackets
- 1 sealing for front side IP 65: GGD4896
- 1 set unit stickers EAK 36
- screw-in/plug-in clamps (according to the model)
- mounting and operating manual

2.2. Function

The GIA 2000 is a universally applicable microprocessor controlled displaying device.

The GIR 2002 is a universally applicable microprocessor controlled displaying, monitoring and controlling device.

Universal input

The device supports one universal interface for the connection of:

- Standard transmitter signals
(0-20 mA, 4-20 mA, 0-50 mV, 0-1 V, 0-2 V and 0-10 V),
- RTD (for Pt100 and Pt1000),
- Thermocouple probes (type K, J, N, T and S),
- Frequency (TTL and switching contact).

As well as flow rate and rotation measuring, counting, etc. ...

The device provides an additional supply for transmitters. See chapter 17 Specification or the corresponding designation on the label on the housing.

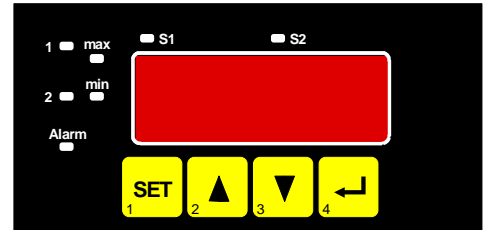

Switching output and alarm

The GIR 2002 features additionally one or two switching outputs, which can be configured as 2-point-controller or min./max. alarm (one switching output) or

2-point-controller, 3-point-controller, 2-point-controller with min./max. alarm, common or individual min./max. alarm (two switching outputs)

The state of the switching outputs (relays) is displayed with the LED's "1" and "2".

An upcoming alarm condition is displayed by LEDs "alarm", "max" and "min".

The devices with the options R3, H3 and N3 are additionally equipped with a 3rd switching output.

With this options the output function 3-point-controller with min./max. alarm are available.

The state of the 3rd switching output is displayed with the LED "S1".

Option analog output

Devices with option AAG are additionally equipped with a scalable analog output (0-10V, 0-20mA or 4-20mA).

Interface

Furthermore both devices supports one EASYBus-interface for communicating with a host computer that makes the device to a full functions EASYBus-module.

Before the GIA 2000 or GIR 2002 can be used, it has to be configured for the customer's application.

Important: At the configuration of the device you have to adjust the input signal (see chapter 6) first and then the analog output function (if available - see chapter 7), the output function (see chapter 8) or the offset-/slope- adjustment (see chapter 9).



In order to avoid undefined input states and unwanted or wrong switching processes, we suggest to connect the device's switching outputs after You have configured the device properly.



By calling a configuration menu (configuration of the measuring input, configuration of the analog output, configuration of the output function, offset- and slope-adjustment) the measurement and regulation of the device will be deactivated.

By leaving the menu the device will be reinitialized and the measuring/regulation will be started again.

At the input function "counter" the counter state will be reset by leaving the menu.

3. Mounting in panels / housings

Panel cut-out

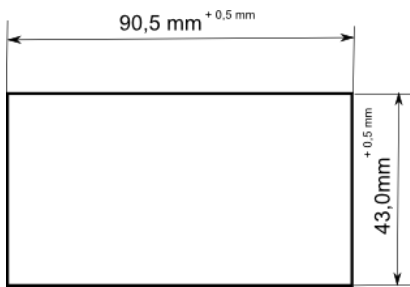

Mounting

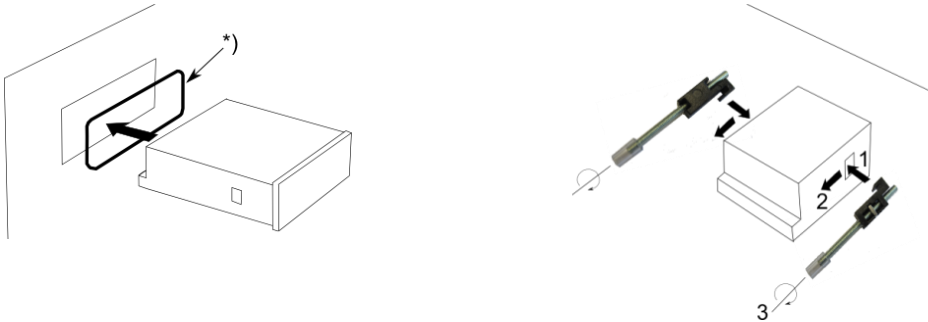

*) sealing GGD4896 is necessary for IP 65! Mount carefully for reliable tightness!

4. Display and operating elements

Front:

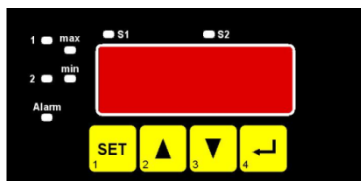

Backside, from top:



4.1. Display elements



Main display:

Display element to show minimum / maximum and measuring value. It also displays errors and parameters.



LED 1:

Indicates the state of output 1 (not active with option analog output)



LED 2:

Indicates the state of output 2



LED alarm:

indicates state of alarm



LED max:

lights up when max. alarm



LED min:

lights up when min. alarm



LED S2:

flashes when tare is active



LED S1

Without function

Option R3, H3 or N3: Indicates the state of output 3

4.2. Operating elements



Button 1:

activates menu "Switching points and alarm boundaries"

Button 1 + 5, >2s: activates menu "Configuration of Output functions"

Menu: **save value or step** to next parameter



Button 2:

display max. value

button 2 + 5, >2s: activates menu „Select input signal“

button 2 + 3, >2s: reset min-/max. value

Menu: press short = increase value

press long = roll-function with overflow-function *)



Button 3:

display min. value

button 3 + 5, >2s: activates menu „Offset- and slope adjustment“

button 3 + 2, >2s: reset min-/max. value

Menu: press short = decrease value

press long = roll-function with overflow-function *)



Button 4:

button 4 + 5: activates menu „Scaling analog output“

Menu: **cancel or terminate the dialog.**

value changes which are not saved with SET will be discharged.

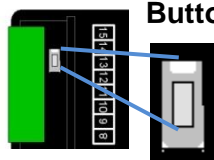

Button 5:

button on the backside (between connection terminals and rear panel)

Function refer button 1..4

*) The buttons 2 and 3 are featured with a 'roll-function'. When pressing the button once the value will be raised (button 2) by one or lowered (button 3) by one. When holding the button pressed for longer than 1 sec. the value starts counting up or down, the counting speed will be raised after a short period of time. The device also features a 'overflow-function', when reaching the upper limit of the range, the device switches to the lower limit, vice versa.

5. Electric connection

Wiring and commissioning of the device must be carried out by skilled personnel only.



ATTENTION

Use the device only for panel mounting or with suitable electrically housings.

The electrical connections must be protected against direct contact

Other way, the risk of an electric shock exists.

In case of wrong wiring the device may be destroyed. We cannot assume any warranty in case of wrong wiring of the device.

5.1. Terminal assignment: Standard

15	EASYBus-Interface
14	EASYBus-Interface
13	Input: 0-10V
12	Input: 0-1V, 0-2V, mA, frequency, Pt100, Pt1000
11	Input: 0-50mV, thermocouples, Pt100
10	Input: GND, Pt100, Pt1000
9	Transmitter supply voltage -
8	Transmitter supply voltage +
7	Output 2: Relay, break contact *1 *2
6	Output 2: Relay, make contact *1 *2
5	Output 2: Relay, input *1 *2
4	Output 1: Relay, make contact, *1 *2 or analog output +
3	Output 1: Relay, input, *1 *2 or analog output -
2	Supply voltage 230 V AC *1
1	Supply voltage 230 V AC *1

*1 = or the corresponding designation on the label on the housing

*2 = not available at GIA 2000

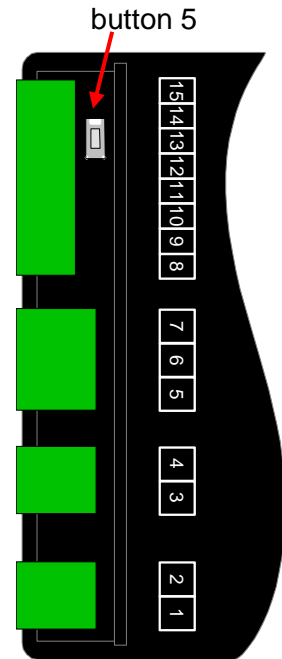

5.2. Terminal assignment for options

5.2.1. At options AA3 and AV3

15	EASYBus-Interface
14	EASYBus-Interface
13	Input: 0-10V
12	Input: 0-1V, 0-2V, mA, frequency, Pt100, Pt1000
11	Input: 0-50mV, thermocouples, Pt100
10	Input: GND, Pt100, Pt1000
9	Transmitter supply voltage -
8	Transmitter supply voltage +
7	Output 2: Relay, break contact, *1
6	Output 2: Relay, make contact, *1
5	Output 2: Relay, input *1
4	Output 1: Relay, make contact *1
3	Output 1: Relay, input *1
	17 Output 3: analog output -
	16 Output 3: analog output +
2	Supply voltage 230 V AC *1
1	Supply voltage V AC *1

*1 = or the corresponding designation on the label on the housing

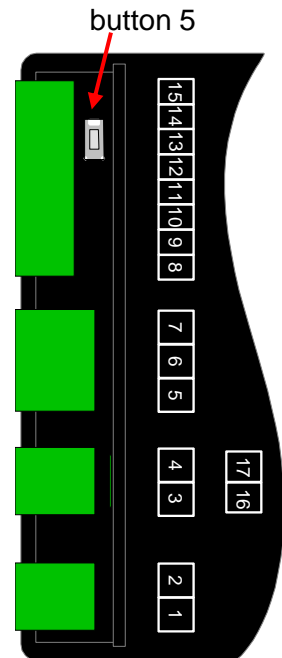

5.2.2. At options R3 or N3

15	EASYBus-Interface
14	EASYBus-Interface
13	Input: 0-10V
12	Input: 0-1V, 0-2V, mA, frequency, Pt100, Pt1000
11	Input: 0-50mV, thermocouples, Pt100
10	Input: GND, Pt100, Pt1000
9	Transmitter supply voltage -
8	Transmitter supply voltage +
7	Output 2: Relay, break contact, * ¹
6	Output 2: Relay, make contact * ¹
5	Output 2: Relay, input, * ¹
4	Output 1: Relay, make contact * ¹
3	Output 1: Relay, input * ¹
	18 Output 3 (alarm): Relay, make contact or -Ua
	17 Output 3 (alarm): Relay, input or NPN-output
	16 Output 3 (alarm): Relay, break contact or +Ua
2	Supply voltage 230 V AC * ¹
1	Supply voltage 230 V AC * ¹

*¹ = or the corresponding designation on the label on the housing

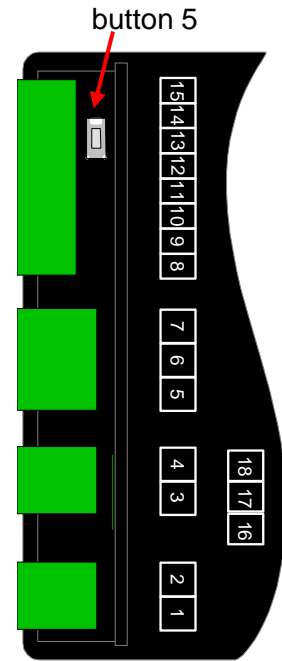

5.2.3. At option H3

15	EASYBus-Interface
14	EASYBus-Interface
13	Input: 0-10V
12	Input: 0-1V, 0-2V, mA, frequency, Pt100, Pt1000
11	Input: 0-50mV, thermocouples, Pt100
10	Input: GND, Pt100, Pt1000
9	Transmitter supply voltage -
8	Transmitter supply voltage +
7	Output 2: Relay, break contact, * ¹
6	Output 2: Relay, make contact, * ¹
5	Output 2: Relay, input, * ¹
4	Output 1: Relay, make contact, * ¹
3	Output 1: Relay, input, * ¹
	17 Output 3 (alarm): control output for external SSR +
	16 Output 3 (alarm): control output for external SSR -
2	Supply voltage 230 V AC * ¹
1	Supply voltage 230 V AC * ¹

*¹ = or the corresponding designation on the label on the housing

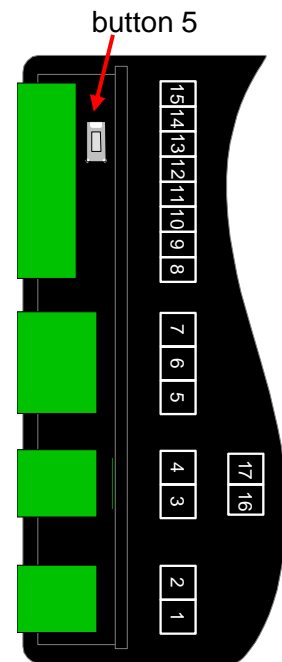

5.2.4. Changes for option H1

4	Output 1: control output for external SSR +
3	Output 1: control output for external SSR -

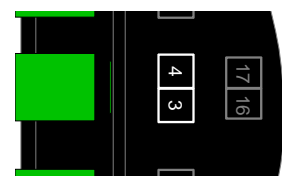

5.2.5. Changes for option H2

6	Output 2: control output for external SSR +
5	Output 2: control output for external SSR -

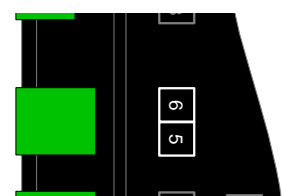

5.3. Connection data



ATTENTION

These limits must not be exceeded (not even for a short time)!

	between terminals	typical		limitations		notes
		min.	max.	min.	max.	
Supply voltage	1 - 2	207 V _{AC}	244 V _{AC}	0 V _{AC}	253 V _{AC}	or according to the type plate
Output 1: Relay: make contact *2 *3	3 - 4				253 V _{AC} 5A ohmic load	or according to the type plate
Output 1: SSR control output *9	3 - 4			0 mA	15 mA	active signal not allowed
Output 1: analog output *4	3 - 4	0-20mA		0 Ω	400 Ω	active signal not allowed
		4-20mA		1000 Ω	∞ Ω	
		0-10V				
Output 2: Relay: change-over contact *2	5, 6, 7				253 V _{AC} 10A ohmic load	or according to the type plate
Output 2: SSR control output *10	5 - 6			0 mA	15 mA	active signal not allowed
Input 0-50mV, TC, ...	11 - 10	0 V	3.3 V	-1 V	10 V, I<10mA	
Input mA	12 - 10	0 mA	20 mA	0 mA	30 mA	
Input 0-1(2)V, freq, ...		0 V	3.3 V	-1 V	30 V, I<6mA	
Input 0-10V	13 - 10	0 V	10 V	-1 V	20 V	
Input Pt100 (Pt1000)	10 - 12			0 Ω	∞ Ω	active signal not allowed
EASYBus-Interface	14 - 15	12 V	36 V	0 V	42 V	
Output 3: analog output *5	16 - 17	0-20mA		0 Ω	400 Ω	active signal not allowed
		4-20mA		1000 Ω	∞ Ω	
		0-10V				
Output 3: Relay: change-over contact *6	16 - 18				30 V _{DC} o. 40 V _{AC} 1A	
Output 3: SSR control output *7	16 - 17			0 mA	15 mA	active signal not allowed
Output 3: NPN-output *8	Ua	16 - 18		0 mA	15 mA	active signal not allowed
	NPN	17 - 18			30 V _{DC} 1A	

*2 not available at GIA 2000

*3 not available at GIR 2002 with options AA1 and AV1

*4 only available with options AA1 and AV1

*5 only available with options AA3 and AV3

*6 only available with options R3

*7 only available with options H3

*8 only available with options N3

*9 only available with options H1

*10 only available with options H2

5.4. Connecting an input signal

Please take care not to exceed the limitations of the inputs when connecting the device as this may lead to destruction of the device.

5.4.1. Connecting a Pt100 RTD probe

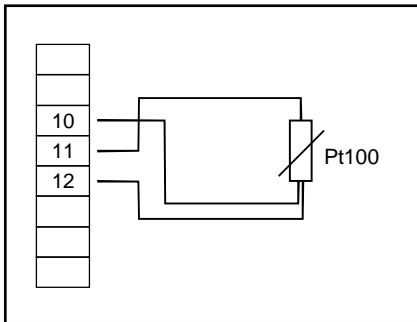

Pt100-RTD probe (3-wire)

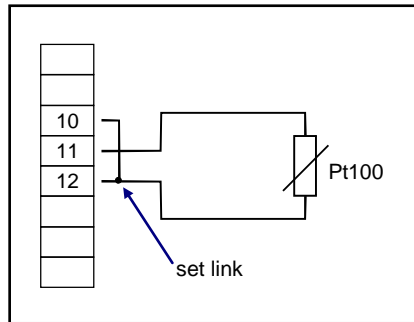

Pt100-RTD probe (2-wire)

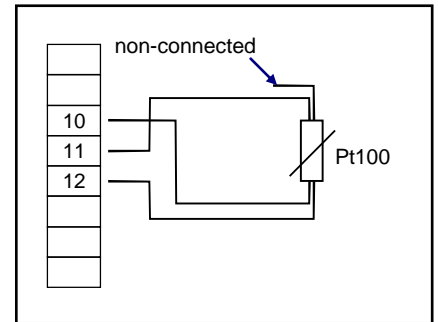

Pt100-RTD probe (4-wire)

5.4.2. Connecting a Pt1000 RTD probe or a thermocouple probe

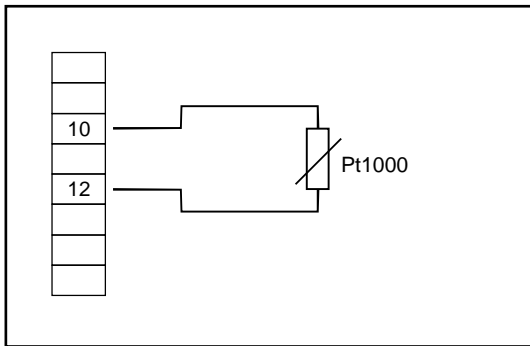

Pt1000-RTD probe (2-wire)

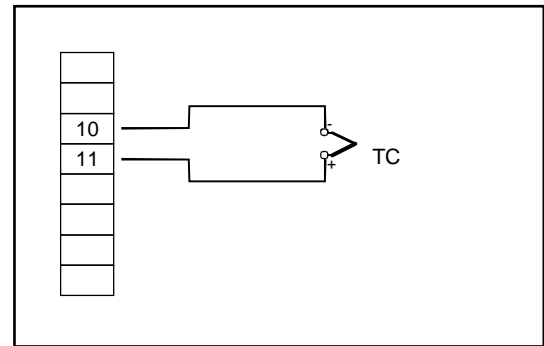

Thermocouple probe

5.4.3. Connecting a 0(4)-20mA transmitter (2-wire- system)

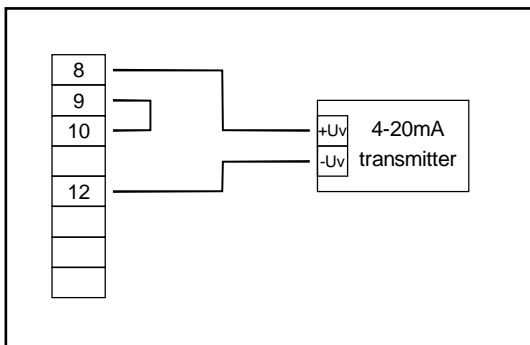

with integrated power supply

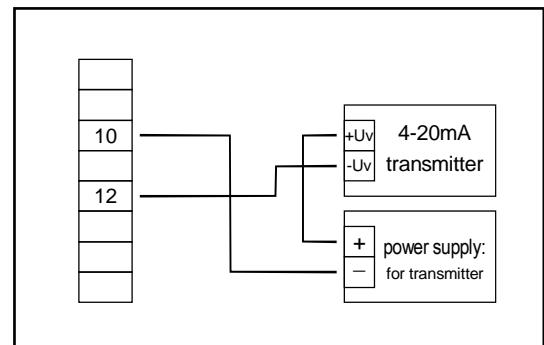

with separate power supply

5.4.4. Connecting a 0(4)-20mA transmitter (3-wire- system)

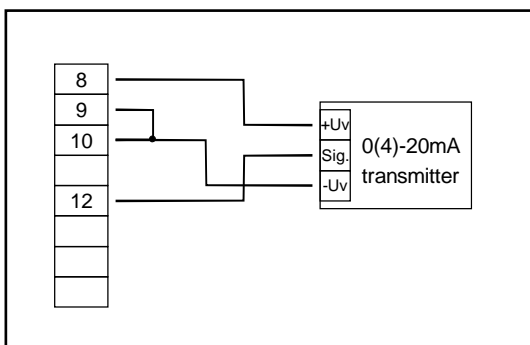

with integrated power supply

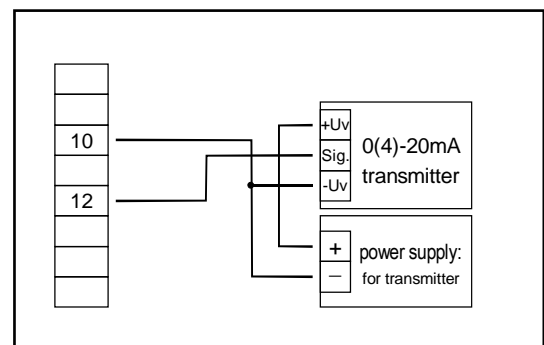

with separate power supply

5.4.5. Connecting a 0-1V, 0-2V or 0-10V transmitter (3-wire-system)

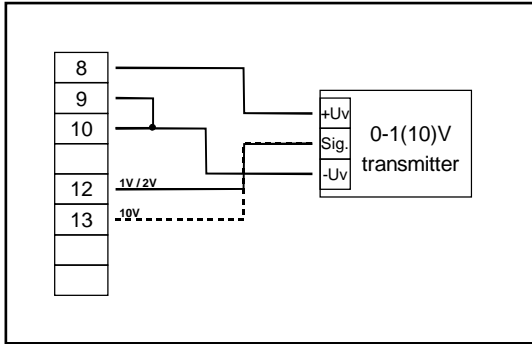

with integrated power supply

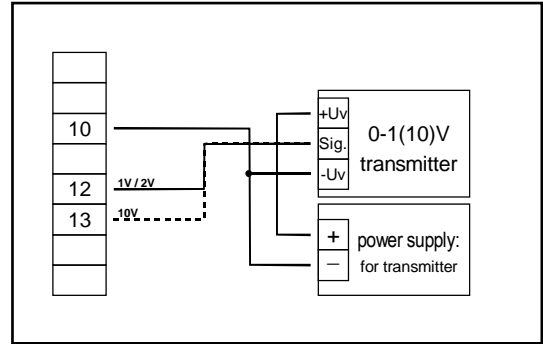

with separate power supply

5.4.6. Connecting a 0-1V, 0-2V or 0-10V or 0-50mV transmitter (4-wire-system)

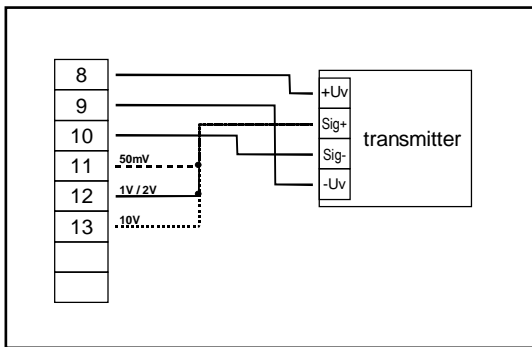

with integrated power supply

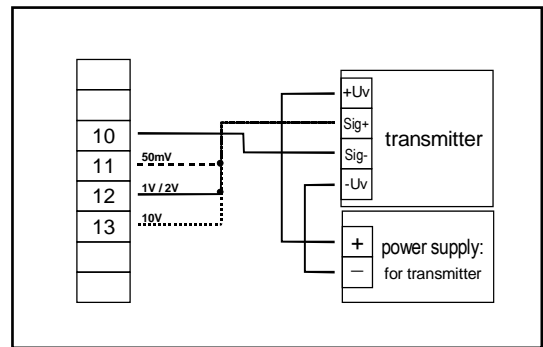

with separate power supply

5.4.7. Connecting a frequency signal

For the measuring of frequency or rotation three different input signals can be selected in the device's configuration. There is the possibility of connecting an active signal (= TTL, ...), a passive sensor-signal with NPN (= NPN-output, push-button, relay, ...) or PNP (= a PNP output switching to +Ub, high-side push-button, ...).

When configuring the device with a NPN switching output, a pull-up-resistor (~7k referring to +3.3V) is connected internally. So when You are using a device with NPN output, You don't need to connect a resistor externally.

When configuring the device with a PNP switching output, a pull-down resistor (~7k referring to GND) is connected internally. So when You are using a device with PNP output, You don't need a resistor externally.

It may be that your measuring-signal source needs the connection of an external resistor e.g. the pull-up-voltage of 3.3V is not enough for the signal source, or you want to measure in the top level frequency range. In this case the input signal has to be treated like an active signal and you have to configure the device as „TTL“.



when connecting the device You have to take care not to exceed the limits of the input voltage respective the input current of the frequency-input.

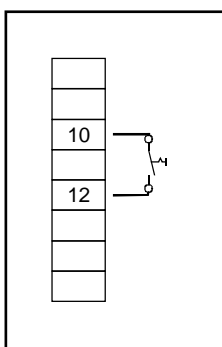

*Connection of a passive contact, push-button
(Configuration: Input = NPN)*

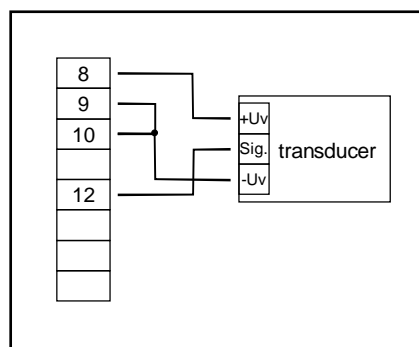

Connection of a transducer (over integrated supply) with TLL, NPN or PNP output

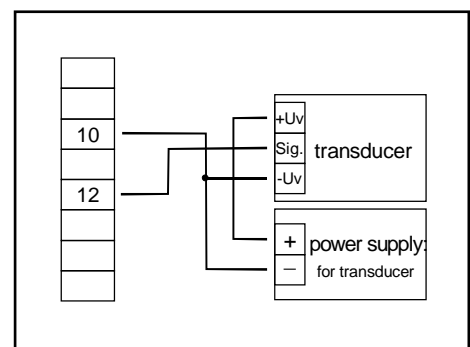

Connection of a transducer (with separate supply) with TLL, NPN or PNP output

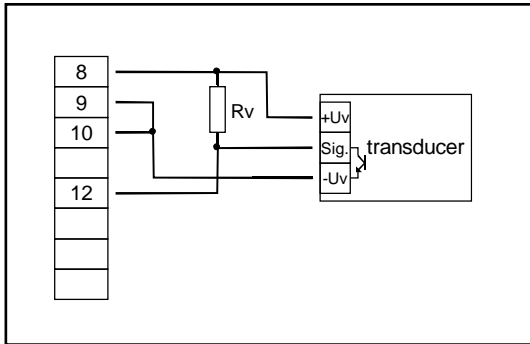

Connection of a transducer (over integrated supply) with NPN output and necessary external resistor

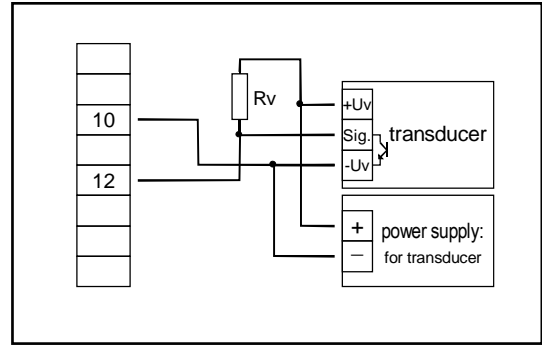

Connection of a transducer (with separate supply) with NPN output and necessary external resistor



Hint:

$R_v = 3k\Omega$ (with power supply voltage = 12V) or $7k\Omega$ (with power supply voltage = 24V), device configuration: Sens = TTL

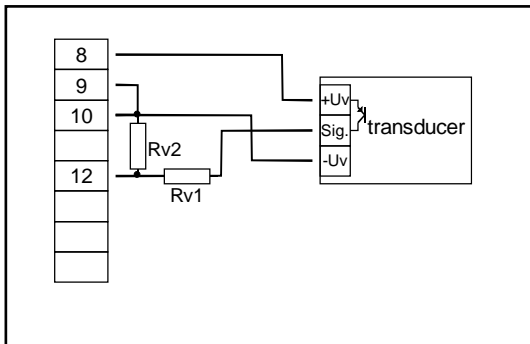

Connecting of a transducer (over integrated supply) PNP output with external resistor wiring.

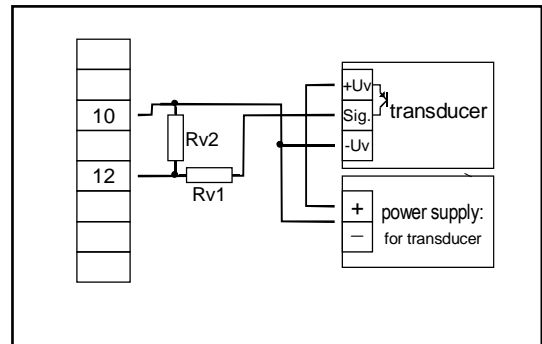

Connecting of a transducer (with separate supply) PNP output and external resistor wiring.



Hint:

$R_{v2} = 600\ \Omega$, $R_{v1} = 1.8k\ \Omega$ (with power supply voltage = 12V) or $4.2k\ \Omega$ (with power supply voltage = 24V), device configuration: Sens = TTL (Rv1 is a current limiting resistor and may be shorted if necessary. It should never exceed the mentioned value.)

5.4.8. Connecting a counter signal

When configuring the device you can select 3 different input signal modes similar to the connection of frequency- and rotation-signals.

The connection of a sensor-signal for a counter-signal is the same used for the frequency- and rotation-signal. Please use the wiring diagram given in this chapter.

There is the possibility to reset the counter. When connecting contact 11 with GND (contact 10) the counter will be reset. You can do this manually (e.g. with the help of a push-button) or automatically (with one switching output of the device – if available).



When connecting the device, take care not to exceed the limits of the input-voltage or the input-current of the frequency input..

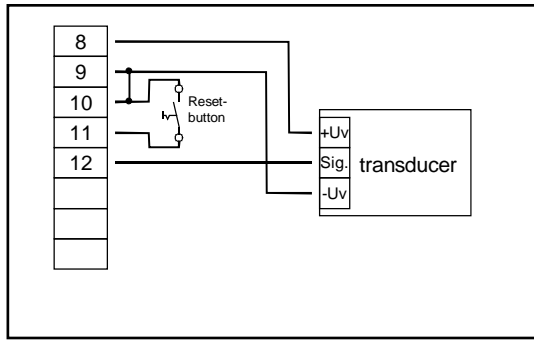

manually reset the device with the help of a push-button

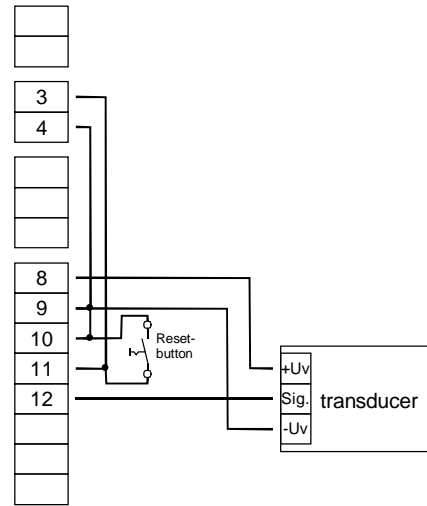

automatically resetting with the help of output 2 and additional resetting the device via push-button

5.5. Connecting switching outputs (only for GIR 2002)



In order to avoid unwanted or wrong switching processes, we suggest to connect the device's switching outputs after you have configured the device's switching outputs properly.



Please take care that you must not exceed the limits of the voltage and of the maximum current of the switching outputs (not even for a short period of time). Please take extreme care when switching inductive loads (like coils or relays, etc.). Because of their high voltage peaks, protective measures (e.g. RC-element) to limit these peaks have to be taken.

When switching high capacitive loads, it is necessary to limit the switch on current by a suitable current limiter (e.g. resistor) to the allowed maximum current.

Take care of light bulbs. Cause a low cold resistance, a high switch on current is possible.



In case of configuring one output as an alarm output, the output will be active in idle state (no alarm present). The output relay opens when an alarm condition occurred

5.5.1. Connection of a solid state relay to the SSR-control output

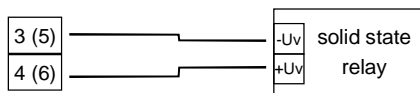

5.6. Common wiring of several devices

At the standard devices the power supply, measuring input, transmitter supply and the serial interface are electrically isolated of each other.

At device options (e.g. dc-supply) it can occur that this isolation is not completely guaranteed (e.g. connection of – power supply to GND).

When interconnecting several of these devices you have to make sure that there is no potential displacement.

6. Configuration of the measuring input

Calling the Configuration

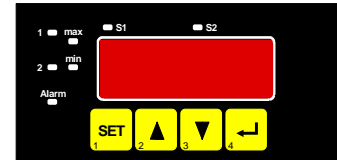

Press the pushbutton on the rear side (button 5) and  together for >2 seconds.



General description and notes to the operating of the menu

The display shows inP ('INPUT').

With button  you can go to the next parameter resp. the new value will be **saved**

With button  or  you can go to the parameter setting and adjust its value there.



With button  settings will be **cancelled** resp. terminated. Changing, are not saved with SET, will be discharged.



If no key is pressed > 10 sec. the adjustment will be cancelled, the changing discarded and it will be changed to the parameter view.

If no key is pressed > 60 sec. the menu will be automatically closed.

6.1. Selecting an input signal type

Input 	Selection  	Input type	Signal	proceed in chapter
inP	U	Voltage signal U	0 – 10 V	6.3
			0 – 2 V	
			0 – 1 V	
			0 – 50 mV	
	I	Current signal I	4 – 20 mA	6.3
			0 – 20 mA	
	t_{RES}	Temperature: RTD	Pt100	6.2
			Pt1000	
	t_{tc}	Temperature: Thermocouples	type K (NiCr-Ni)	6.2
			type S (Pt10Rh-Pt)	
			type N (NiCrSi-NiSi)	
			type J (Fe-CuNi)	
			type T (Cu-CuNi)	
$FREQ$	Frequency	TTL-signal	6.4	
		Switch-contact NPN, PNP		
$FlowP$	Flow rate	TTL-signal	6.5	
		Switch-contact NPN, PNP		
rPn	Rotation	TTL-signal	6.6	
		Switch-contact NPN, PNP		
$Co.up$	Counter up	TTL-signal	0	
		Switch-contact NPN, PNP		
$Co.dn$	Counter down	TTL-signal	0	
		Switch-contact NPN, PNP		
$SERi$	Interface mode	Serial interface	6.8	



When changing the measuring mode “InP” all settings will be reset. Therefore you have to set all the other settings of the input configuration again.





When changing the measuring mode “InP” the values for the offset and slope-adjustment will be reset. Furthermore a change of the device scaling for standard signals (di.Lo, di.Hi, dP) or of the resolution and unit for temperature can possibly influence the values of the offset and slope-adjustment. Therefore you may check your offset and slope-adjustment after changing the input configuration.

The change of the device scaling for standard signals (di.Lo, di.Hi, dP) or of the resolution and unit for temperature can possibly change the switching and alarm points. Therefore you may check your output settings afterwards!

6.2. Measuring temperature (Pt100, Pt1000 RTD probes and thermocouple type J, K, N, S or T)

This chapter describes how to configure the device for temperature measuring with the help of external platinum RTD probes or thermocouple probes. This instruction demands that you selected “t.res” or “t.tc” as input type like it is explained in chapter 6.1.

The display must show *InP*.

Parameter 	Value  	Description	Notes
<i>SEnS</i> (with <i>t.res</i>)	<i>100</i>	Pt100 (3-wire)	Meas.-range: -50.0 ... +200.0 °C (-58.0 ... + 392.0 °F)
	<i>1000</i>	Pt1000 (2-wire)	Meas.-range:: -200 ... + 850 °C (-328 ... + 1562 °F)
<i>SEnS</i> (with <i>t.tc</i>)	<i>n cr</i>	type K (NiCr-Ni)	Meas.-range: -270 ... +1372 °C (-454 ... + 2502 °F)
	<i>5</i>	type S (Pt10Rh-Pt)	Meas.-range:: -70.0 ... +250.0 °C (-94.0 ... + 482.0 °F)
	<i>n</i>	type N (NiCrSi-NiSi)	Meas.-range:: -270 ... +1350 °C (-454 ... + 2462 °F)
	<i>J</i>	type J (Fe-CuNi)	Meas.-range:: -170 ... + 950 °C (-274 ... + 1742 °F)
	<i>t</i>	type T (Cu-CuNi)	Meas.-range:: -270 ... + 400 °C (-454 ... + 752 °F)
	<i>t</i>		Meas.-range:: -70.0 ... +200.0 °C (-94.0 ... + 392.0 °F)
<i>rES</i>	0.1° or 1°	resolution	
<i>Unit</i>	°C or °F	unit	
<i>Filter</i>	<i>OFF</i> , 0.01 ... 2.00 s	filter	see info filter

Finish configuration:

Press Button  till display shows *InP* again.

Now press button  to leave the menu.

F_i Lt: filter

this filter is a digital replica of a low pass filter..



If the digital filter is "off" the internal mains hum suppression of the GIR2002 is deactivated. This adjustment is ideal for fastest response to even small changes of the signal, but the display and the analog output gets more turbulent. Therefore the filter should set to at least 0.01 for 'ordinary' application

A filter value of at least 0.1 is recommended for the input type S.

6.3. Measuring voltage and current (0-50mV, 0-1V, 0-2V, 0-10V, 0-20mA, 4-20mA)

This chapter describes how you configure the device for measuring voltage- or current-signals from an external transmitter. This instruction demands that you selected "U" or "I" as input type like it is explained in chapter 6.1

The display must show *lnP*.

Parameter 	Value  	Notes
SEnS (with U)	10.00	0 – 10 V
	2.00	0 – 2 V
	1.00	0 – 1 V
	0.050	0 – 50 mV
SEnS (with I)	4-20	4 – 20 mA
	0-20	0 – 20 mA
dP	"- - - -" "- - - . -" "- . - - -" "- . - . -"	Decimal point
d _i Lo	-1999 ... 9999	Lower display value
d _i Hi	-1999 ... 9999	High display value
L _i (Limit)	oFF	Exceeding of the measuring range limit is tolerable until the measuring limit. (see info "limit")
	onEr	The measuring range limit is exactly bounded by the input signal. When exceeding or short falling the input signal the device will display an error message
	onrG	The measuring range limit is exactly bounded by the input signal. When exceeding or short falling the input signal the device will display the selected lower/upper display value. <i>e.g. humidity: when exceeding, the device will display 0% or 100%</i>
F _i Lt	oFF, 0.01 ... 2.00 s	filter (see info filter)

Finish configuration:

Press Button  till display shows *lnP* again.

Now press button  to leave the menu.

L₁ : limit

When exceeding the measuring limit (~ upper measuring range + 5% or 21.0 mA at 4-20mA) independently from the limit setting, the device will always display the corresponding error message ("Err.1"). When short falling the measuring limit 3.6 mA) independently from the limit setting, the device will always be displaying the corresponding error message ("Err.2"), if the input signal 4-20mA is chosen. A short falling of 0V or 0mA is not detected..

F₁ Lt: filter



If the digital filter is "off" the internal mains hum suppression of the GIR2002 is deactivated. This adjustment is ideal for fastest response to even small changes of the signal, but the display and the analog output gets more turbulent. Therefore the filter should set to at least 0.01 for 'ordinary' application a filter value of at least 0.1 is recommended for the input signal 0-50mV

6.4. Measuring of frequency (TTL, switching-contact)

This chapter describes how to configure the device for measuring frequency.

This instruction demands that you selected "FrEq" as input type like it is explained in chapter 6.1.

The display must show *lnP*.

Parameter 	Value  	Note
<i>SEnS</i>	<i>tTL</i>	TTL-signal (see info connection)
	<i>nPn</i>	Switching contact, NPN For direct connection of a passive switching contact (e.g. push button, relay) or transmitter with NPN output. There is a internal pull-up-resistor. (see info switching contact)
	<i>PnP</i>	Switching contact, PNP For direct connection of a transmitter with PNP output. There is a internal pull-down-resistor.
<i>Fr.Lo</i>	<i>0 ... 9999</i>	lower frequency range
<i>Fr.Hi</i>	<i>Fr.Lo ... 9999</i>	upper frequency range
<i>dP</i>	"- - - -" " . - - - " "- . - - -" "- . - . - -"	Decimal point
<i>di.Lo</i>	<i>-1999 ... 9999</i>	display at lower frequency range limit
<i>di.Hi</i>	<i>-1999 ... 9999</i>	display at upper frequency range limit
<i>L₁</i> (Limit)	<i>oFF</i>	Exceeding of the measuring-frequency is tolerable until you reach the maximum measuring range limit.
	<i>on.Er</i>	The measuring range is exactly bounded by the selected frequency-measuring-range-limit. When exceeding or short falling of the limit the device will display an error message
	<i>on.rG</i>	The measuring range is exactly bounded by the selected measuring-range-limit. When exceeding or short falling of the limit the device will display the lower or upper display-range-limit. <i>e.g. humidity:</i> <i>when exceeding, the device will display 0% or 100%</i>
<i>F₁ Lt</i>	<i>oFF,</i> <i>0.01 ... 2.00 s</i>	Filter

Finish configuration:

Press Button  till display shows *InP* again.

Now press button  to leave the menu.

Switching contact, NPN:

when using push-buttons or relays, they must be bounce-free!

Connection:

For the connection of a frequency-transmitter, please follow the instructions given in chapter 5.4.7
When connecting a switching-contact-transmitter with increased frequency range (= with external circuitry) you have to select TTL as input signal.

Measuring:



When exceeding the maximum range limit (10kHz) independently from the limit setting an error message will be displayed ("Err.1").

6.5. Measuring of flow rate (TTL, switching-contact)

This chapter describes how to configure the device for measuring flow rate

This instruction demands that you selected "**Flo.P**" as input type like it is explained in chapter 6.1.

The display must show *InP*.

Parameter 	Value  	Note
<i>SEnS</i>	<i>tTL</i>	TTL-signal (see info connection)
	<i>nPN</i>	Switching contact, NPN For direct connection of a passive switching contact (e.g. push button, relay) or transmitter with NPN output. There is a internal pull-up-resistor (see info switching contact)
	<i>PnP</i>	Switching contact, PNP For direct connection of a transmitter with PNP output. There is a internal pull-down-resistor.
<i>PuPL</i>	<i>1 ... 1000</i>	Pulses per litre
<i>Unit</i>	<i>LPS</i>	litre / second
	<i>LPh</i>	litre / hour
	<i>LpM</i>	litre / minute
<i>dP</i>	"- - - -" "- - - ." "- . - - -" "- . - - -"	Decimal point
<i>Flt</i>	<i>off,</i> <i>0.01 ... 2.00 s</i>	Filter

Finish configuration:

Press Button  till display shows *InP* again.

Now press button  to leave the menu.

Switching contact, NPN:

When using push-buttons or relays, they must be bounce-free!

Connection:



For the connection of a frequency-transmitter, please follow the instructions given in chapter 5.4.7. When connecting a switching-contact-transmitter with increased frequency range (= with external circuitry) you have to select TTL as input signal.

6.6. Measuring of rotation speed (TTL, switching-contact)

This chapter describes how to configure the device for measuring rotation speed.

This instruction demands that you selected "rPn" as input type like it is explained in chapter 6.1.

The display must show ln^P .

Parameter 	Value  	Note
$SEN5$	tTL	TTL-signal (see info connection)
	nPn	Switching contact, NPN For direct connection of a passive switching contact (e.g. push button, relay) or transmitter with NPN output. There is a internal pull-up-resistor
	PnP	Switching contact, PNP For direct connection of a transmitter with PNP output. There is a internal pull-down-resistor.
diu	$1 \dots 1000$	divisor
dP	"- - - -" "- . - . -" "- . . - . -" "- . . . - . -" "- -"	Decimal point (see info decimal point)

Finish configuration:

Press Button  till display shows ln^P again.

Now press button  to leave the menu.

Decimal point:

Use the decimal point position to change the resolution of your measurement. The more the decimal point position is on the left, the finer the resolution will become. Please note that you lower the maximum value that can be displayed, either

Example:

50 rotations per minute.

without decimal point: display = 50, the maximum value 9999 rotations per minute.

decimal point on the left e.g. XX.XX: display = 50.00, maximum value 99.99 rotations per minute.

Connection:

For the connection of a frequency-transmitter, please follow the instructions given in chapter 5.4.7. When connecting a switching-contact-transmitter with increased frequency range (= with external circuitry) you have to select TTL as input signal.

6.7. Up-/Downwards counter (TTL, switching-contact)

The upwards counter starts counting upwards from 0 according to its settings.

The downwards counter starts counting downwards from the selected upper value.



The present value of the counter can be reset anytime by connecting pin 11 to GND (pin 10). The counter starts from its beginning as you disconnect pin 11 and pin 10.

Feature: The present counter value won't be lost if the voltage supply is disconnected. The counter starts from this value after restarting.

This chapter describes how to configure the device as a counter.

This instruction demands that you selected "Co.up" or "Co.dn" as input type like it is explained in chapter 6.1

The display must show *lnP*.

Parameter 	Value  	Note
<i>SEnS</i>	<i>tTL</i>	TTL-signal
	<i>nPn</i>	Switching contact, NPN For direct connection of a passive switching contact (e.g. push button, relay) or transmitter with NPN output. There is a internal pull-up-resistor.
	<i>PnP</i>	Switching contact, PNP For direct connection of a transmitter with PNP output. There is a internal pull-down-resistor.
<i>EDGE</i>	<i>Pos</i>	The counter is triggered on the positive (rising) edge.
	<i>nEG</i>	The counter is triggered on the negative (falling) edge.
<i>di u</i>	<i>1 ... 1000</i>	divisor (see info divisor)
<i>Co.Hi</i>	<i>0 ... 9999</i>	Upper counting range limit The lower counter-range-limit (downwards counter) is fixed with 0.
<i>dP</i>	"-.-.-" ".-.-." "-.-.-" ".-.-."	Decimal point
<i>di .Hi</i>	<i>-1999 ... 9999</i>	Upper counting range limit
<i>L_i</i> (Limit)	<i>off</i>	Exceeding of the counter range is tolerable until you reach the maximum measuring range limit.
	<i>on.Er</i>	The measuring range is exactly bounded by the selected counter-range-limit. When exceeding or short falling of the limit the device will display an error message.
	<i>on.rG</i>	The measuring range is exactly bounded by the selected counter-range-limit. When exceeding or short falling of the limit the device will display the upper counter-range-limit or 0.

Finish configuration:

Press Button  till display shows *lnP* again.

Now press button  to leave the menu.

Connection:

For the connection of a frequency-transmitter, please follow the instructions given in chapter 5.4.8. When connecting a switching-contact-transmitter with increased frequency range (= with external circuitry) you have to select TTL as input signal..

Divisor:

The incoming pulses will be divided with the selected pre-scaling factor, after that they will be transmitted to the device for further processing. By this factor you can adapt the device to your transmitter or select a pre-scaling factor for large values.

Example:

Your transmitter emits 1800 pulses per litre and you expect a flow rate of 300 litres. The display should be in litre with a resolution of 0.1 litres.

The pulses to be counted are 1800 Impulses * 300 litres, would result 540000 in Impulses. This overrides the upper counter range. By setting the pre-scaling factor of 100 the pulses are reduced to 540000/100 = 5400. The upper counting range limit has to be set to 5400.

The display should have a resolution of 0.1 liters. the decimal point position has to be ---.- and a display range limit of 300.0

6.8. Interface mode



When the device is in the interface mode it won't make any measurements by itself. The value shown in the device's display is sent via serial interface. But the switching and alarm functions of the displayed value are still available.

The EASYBus-Address of the device needed for the communication can be set manually with the device itself or with the help of an EASYBus-software (like Easybus Configurator). Please note, when carrying out an EAYBus-system-initialisation the device's address will be reset automatically.

This chapter describes how to configure the device as an EASYBus-display.

This instruction demands that you selected "SEri" as input type like it is explained in chapter 6.1

The display must show *lnP*.

Parameter 	Value  	Note
<i>Adr</i>	0 ... 239	Address
<i>dP</i>	"- - - -" " - . - - -" " . - . - -" " - . - - -"	Decimal point

Finish configuration:

Press Button  till display shows *lnP* again.

Now press button  to leave the menu.

7. Configuration of the analog output (only with option AAG)

Calling the Configuration

Press the pushbutton on the rear side (button 5) and  together for >2 seconds.

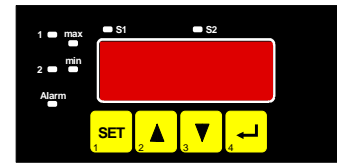

The display shows "dA.ou" resp. "dA.Lo".

The analog output can be scaled arbitrary within the display range.



General description and notes to the operating of the menu

With button  you can go to the next parameter resp. the new value will be **saved**

With button  or  you can go to the parameter setting and adjust its value there.

With button  settings will be **cancelled** resp. terminated. Changing, are not saved with SET, will be discharged.





If you don't press any button for more than 10 sec. in the parameter setting, the adjustment will be cancelled, the changing discarded and it will be changed to the parameter view. If you don't.



A change of the input configuration can possibly influence the configuration of the analog output. (e.g. changing of scaling for standard signals or changing of resolution or unit for temperature). Therefore the analog output configuration should be done after the input configuration has been finished. Additionally you may check your analog output settings after the input configuration has been changed.

7.1. Scaling the analog output

The display must show *dA.ou* resp. *dA.Lo*.

Parameter 	Value  	Note
<i>dA.ou</i> *) 0(4)...20mA	4-20	Output signal 4..20mA
	0-20	Output signal 0..20mA"
<i>dA.Lo</i>	-9999 ... 9999	Low analog output value
<i>dA.Hi</i>	-9999 ... 9999	High analog output value
<i>dA.Fi</i> , only with <i>U, I</i> und <i>FrEq</i>	<i>d, SP</i>	The filter for the display takes effect on the analog output. The resolution of the analog output depends on the scaling of the display.
	<i>1...200</i>	Analog output is independent of the filter for the display. It works with the highest possible resolution.
<i>dA.Er</i>	<i>Lo</i>	Inactive in case of an error. output signal = 0 mA or 0 V.
	<i>Hi</i>	Active in case of an error. output signal = >23 mA or >10.5 V

*) not with 0-10V analog output

Finish configuration:

Press Button  till display shows *dA.ou* resp. *dA.Lo* again.

Now press button  to leave the menu.

8. Configuration of the output functions (only for GIR 2002)

Calling the Configuration

Press the pushbutton on the rear side (button 5) and  together for >2 seconds.

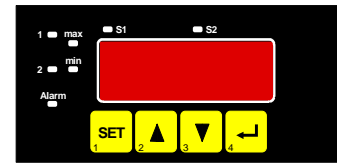

The display shows "outP".

The output can be scaled arbitrary within the display range.



General description and notes to the operating of the menu

With button  you can go to the next parameter resp. the new value will be **saved**

With button  or  you can go to the parameter setting and adjust its value there.

With button  settings will be **cancelled** resp. terminated. Changing, are not saved with SET, will be discharged.



If no key is pressed > 10 sec. the adjustment will be cancelled, the changing discarded and it will be changed to the parameter view.



If no key is pressed > 60 sec. the menu will be automatically closed.



A change of the input configuration can possibly influence the switching points and alarm boundaries. (e.g. changing of scaling for standard signals or changing of resolution or unit for temperature). Therefore the output configuration and switching points / alarm boundaries adjustment should be done after the input configuration has been finished.

Additionally you may check your output settings after the input configuration has been changed..

8.1. Selection of the output function

Output 	Function  	Output 1 (make contact)	Output 2 (change-over contact)	Output 3 ^{*3}	Note	See chapter
outP	no	off	off	off	No output, only display unit	--
	2P	Switching function 1 ^{*2}	off ^{*2}	off	2-point-controller	8.2
	3P	Switching function 1	Switching function 2	off	3-point-controller ^{*1}	8.2
	2PAL	Switching function 1	Min-/Max-alarm, inverse ^{*4}	off	2-point-controller with Min-/Max-alarm ^{*1}	8.3
	3PAL	Switching function 1	Switching function 2	Min-/Max-alarm, inverse ^{*4}	3-point-controller with Min-/Max-alarm ^{*3}	8.3
	ALF1	off	Min-/Max-alarm, inverse ^{*4}	off	Min-/Max-alarm, common	8.4
	ALF2	Min-/Max-alarm, inverse ^{*4}	Min-/Max-alarm, inverse ^{*4}	off	Min-/Max-alarm, individual ^{*1}	8.4

^{*1} not available with option AA1 and AV1, output 1 is analog output.

^{*2} at option Ax...1 the switching function1 is allocated to output 2, output 1 is analog output

^{*3} Function and output are only existing with the options R3, H3 and N3.

^{*4} Alarm inverse means, that the output will be active when there is no alarm!

Finish configuration:

Press Button  till display shows *outP* again.



Now press button  to leave the menu.

The settings for the switching and alarm points can be made later in an extra menu.

8.2. 2-point-controller, 3-point-controller

This chapter describes how to configure the device as a 2-point-controller or 3-point-controller and how to adjust the switching values. This instruction demands that you selected "2P" or "3P" as output function like it is explained in chapter 8.1.

The display must show *OutP*.

Parameter 	Value  	Note
<i>1.on</i>	Min. display range ... Max. display range	turn-on-point of switching function 1
<i>1.off</i>	Min. display range ... Max. display range	turn-off-point of switching function 1
<i>1.dEL</i>	<i>0.01 ... 2.00</i>	Delay of switching function 1 (see info switching delay)
<i>1.Err</i>	<i>off</i>	Inactive in case of an error
	<i>on</i>	Active in case of an error
<i>2.on</i> only with 3P	Min. display range ... Max. display range	turn-on-point of switching function 2
<i>2.off</i> only with 3P	Min. display range ... Max. display range	turn-off-point of switching function 2
<i>2.dEL</i> only with 3P	<i>0.01 ... 2.00</i>	Delay of switching function 2 (see info switching delay)
<i>2.Err</i> only with 3P	<i>off</i>	Inactive in case of an error
	<i>on</i>	Active in case of an error

Finish parameter input:

Press Button  till display shows *outP* again.

Now press button  to leave the menu.

Switching delay:

The value for the switching-delay is the time [in sec] the device waits at least to switch on the output again after the output was switched off..

8.3. 2-point-controller with alarm function, 3-point-controller with alarm function

This chapter describes how to configure the device as a 2-point-controller with alarm function or 3-point-controller with alarm function how to adjust the switching values and alarm boundaries. This instruction demands that you selected "2P.AL" or "3P.AL" as output function like it is explained in chapter 8.1.





ATTENTION

The alarm-outputs are inverted!

This means, that the output will be active when there is no alarm!

The display must show *OutP*.

Parameter 	Wert  	Beschreibung
<i>1.on</i>	Min. display range ... Max. display range	turn-on-point of switching function 1
<i>1.off</i>	Min. display range ... Max. display range	turn-off-point of switching function 1
<i>1.dEL</i>	<i>0.01 ... 2.00</i>	Delay of switching function 2 1 (see info switching delay)
<i>1.Err</i>	<i>off</i>	Inactive in case of an error
	<i>on</i>	Active in case of an error
<i>2.on</i> only with 3P	Min. display range ... Max. display range	turn-on-point of switching function 2
<i>2.off</i> only with 3P	Min. display range ... Max. display range	turn-off-point of switching function 2
<i>2.dEL</i> only with 3P	<i>0.01 ... 2.00</i>	Delay of switching function 2 (see info switching delay)
<i>2.Err</i> only with 3P	<i>off</i>	Inactive in case of an error
	<i>on</i>	Active in case of an error
<i>AL.Hi</i>	<i>ALL o</i> ... Max. display range	maximum alarm-value
<i>ALL o</i>	Min. display range ... <i>AL.Hi</i>	minimum alarm-value
<i>A.dEL</i>	<i>0 ... 9999</i>	Alarm delay. Time [in sec] before the alarm gets active.

Finish parameter input:

Press Button  till display shows *OutP* again.

Now press button  to leave the menu.

Switching delay:

The value for the switching-delay is the time [in sec] the device waits at least to switch on the output again after the output was switched off.



8.4. Min-/Max-Alarm (individual or common)

This chapter describes how to adjust the device's alarm boundaries for min-/max-alarm-monitoring. This instruction demands that you selected "AL.F1" or "AL.F2" as output function like it is explained in chapter 8.1.



The alarm-outputs are inverted!
This means, that the output will be active when there is no alarm!

The display must show *OutP*.

Parameter 	Wert  	Beschreibung
<i>AL.Hi</i>	<i>ALLo</i> ... Max. display range	maximum alarm-value
<i>ALLo</i>	Min. display range ... <i>AL.Hi</i>	minimum alarm-value
<i>A.dEL</i>	<i>0 ... 9999</i>	Alarm delay. Time [in sec] before the alarm gets active.

Finish parameter input:

Press Button  till display shows *outP* again.

Now press button  to leave the menu.

9. Offset- and slope-adjustment

The offset and slope-adjustment function can be used for compensating the tolerance of the used sensor, and for vernier adjustment of the used transducer or transmitter.



The size of the offset- and slop-menu depends on the selected input signal. Therefore it could happen that a menu item is not available or that the whole menu can not be called at all.



When changing the measuring mode "InP" the values for the offset and slope-adjustment will be reset. Furthermore a change of the device scaling for standard signals (di.Lo, di.Hi) or of the resolution and unit for temperature can possibly influence the values of the offset and slope-adjustment. Therefore the offset- and slope-adjustment should be done after the input configuration has been finished. Additionally you may check your offset and slope-adjustment after changing the input configuration.

Calling the configuration

Press the pushbutton on the rear side (button 5) and  together for >2 seconds.

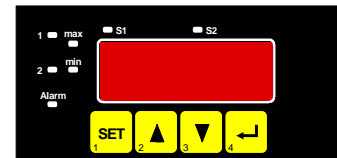

The display shows "OFFS".

The output can be scaled arbitrary within the display range.



General description and notes to the operating of the menu

With button  you can go to the next parameter resp. the new value will be **saved**

With button  or  you can go to the parameter setting and adjust its value there.

With button  settings will be **cancelled** resp. terminated. Changing, are not saved with SET, will be discharged.





If no key is pressed > 10 sec. the adjustment will be cancelled, the changing discarded and it will be changed to the parameter view.

If no key is pressed > 60 sec. the menu will be automatically closed.

9.1. Menu calling and adjustment

The display must show **OFFS**.

Parameter 	Value  	Note
OFFS	$\pm 10\%$ FS	Offset The input of the offset will be in digit or °C/°F. The value that had been set will be subtracted from the measured value.
SCAL	$\pm 5.00\%$	Scale

Finish parameter input:

Press Button  till display shows **OFFS** again.

Now press button  to leave the menu.

Calculate correction:

Temperature:

Displayed value = (measured value – zero point offset) * (1 + slope adjustment [% / 100])

Standard signal:

Displayed value = (measured value – zero point offset - di.Lo) * (1 + slope adjustment [% / 100]) + di.Lo

Examples for offset- and slope-adjustment:

Example 1: Connecting a Pt1000-sensor (with an offset error depending on the cable-length of the sensor)

The device displays the following values (without offset- or slope-adjustment): 2°C at 0°C and 102°C at 100°C

Therefore you calculated: zero point: 2

slope: $102 - 2 = 100$ (deviation = 0)

You have to set: offset = 2 (= zero point-deviation)
scale = 0.00

Example 2: Connecting of a 4-20mA-pressure-transducer

The device displays the following values (without offset- or slope-adjustment): 0.08 at 0.00 bar and 20.02 at 20.00 bar

Therefore you calculated: zero point: 0.08

slope: $20.02 - 0.08 = 19.94$

deviation: 0.06 (= target-slope – actual-slope = 20.00 - 19.94)

You have to set: offset = 0.08 (= zero point-deviation)
scale = 0.30 (= deviation / actual-slope = 0.06 / 19.94 = 0.0030 = 0.30%)

Example 3: Connecting of a flow-rate-transducer

The device displays the following values (without offset- or slope-adjustment): 0.00 at 0.00 l/min and 16.17 at 16.00 l/min

Therefore you calculated: zero point: 0.00

slope: $16.17 - 0.00 = 16.17$

deviation: - 0.17 (=target-slope – actual slope = 16.00 - 16.17)

You have to set: offset = 0.00
scale = - 1.05 (= deviation / actual-slope = - 0.17 / 16.17 = - 0.0105 = - 1.05%)

10. Switching points and alarm-boundaries (only for GIR 2002)



The difference between this menu and the output configuration menu is that only in the output configuration menu it is possible to select the output function and to adjust the delay and the preferred state of switching functions.

Calling the Menu

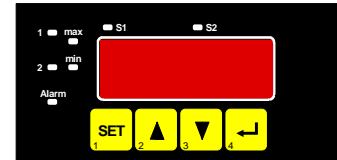

Press the  for >2 seconds.

Depending on the configuration you have made in the output configuration menu you will get different display values. Please follow the specific chapter for further information.



General description and notes to the operating of the menu

With button  you can go to the next parameter resp. the new value will be **saved**

With button  or  you can go to the parameter setting and adjust its value there.

With button  settings will be **cancelled** resp. terminated. Changing, are not saved with SET, will be discharged.



If no key is pressed > 10 sec. the adjustment will be cancelled, the changing discarded and it will be changed to the parameter view.
If no key is pressed > 60 sec. the menu will be automatically closed.



A change of the input configuration can possibly influence the switching points and alarm boundaries. (e.g. changing of scaling for standard signals or changing of resolution or unit for temperature)

Therefore you may check your output settings after the input configuration has been changed.

10.1. Menu calling

Selected <i>OutP</i>	Note	Go on in chapter
<i>no</i>	No output, device is only display <i>Menu not available</i>	--
<i>2P</i>	2-point-controller	10.2
<i>3P</i>	3-point-controller	10.2
<i>2P.AL</i>	2-point-controller with min-/max-alarm	10.3
<i>3P.AL</i>	3-point-controller with min-/max-alarm	10.3
<i>AL.F1</i>	min-/max-alarm, common	10.4
<i>AL.F2</i>	min-/max-alarm, individual	10.4





At devices with the options AA1 and AV1 the output functions 3P, 2P.AL and AL.F2 are not available. The output function 3P.AL is only available with the option R3, H3 and N3.

10.2. 2-point-controller, 3-point-controller

This chapter describes device how to adjust the switching values of the device used as a 2-point-controller or 3-point-controller. This instruction demands that you selected "2P" or "3P" as output function like it is explained in chapter 8.1.

The display must show *1.on*.

Parameter 	Wert  	Beschreibung
<i>1.on</i>	Min. display range ... Max. display range	turn-on-point of switching function 1
<i>1.off</i>	Min. display range ... Max. display range	turn-off-point of switching function 1
<i>2.on</i> only with 3P	Min. display range ... Max. display range	turn-on-point of switching function 2
<i>2.off</i> only with 3P	Min. display range ... Max. display range	turn-off-point of switching function 2

Finish parameter input:

Press Button  till display shows *1.on* again.

Now press button  to leave the menu.



Example: You want to control the temperature of a heating coil, with a hysteresis of +2°C, to 120°C. Therefore you will have to select the turn-on-point "1.on" to 120°C and the turn-off-point to "122°C". When your heating coil temperature falls below 120°C it will be turned on. When the temperature rises above 122°C the heating coil will be turned off.

Note: Depending on the inertia of your heating coil an overshooting of the temperature may be possible.

10.3. 2-point-controller with alarm function, 3-point-controller with alarm function

This chapter describes how to adjust the switching values and alarm boundaries for the device used as a 2-point-controller with alarm function or 3-point-controller with alarm function. This instruction demands that you selected "2P.AL" or "3P.AL" as output function like it is explained in chapter 8.1.

The display must show *1.on*.

Parameter 	Wert  	Beschreibung
<i>1.on</i>	Min. display range ... Max. display range	turn-on-point of switching function 1
<i>1.off</i>	Min. display range ... Max. display range	turn-off-point of switching function 1
<i>2.on</i> only with 3P	Min. display range ... Max. display range	turn-on-point of switching function 2
<i>2.off</i> only with 3P	Min. display range ... Max. display range	turn-off-point of switching function 2
<i>AL.Hi</i>	<i>AL.Lo</i> ... Max. display range	maximum alarm-value
<i>AL.Lo</i>	Min. display range ... <i>AL.Hi</i>	minimum alarm-value
<i>R.dEL</i>	<i>0 ... 9999</i>	Alarm delay. Time [in sec] before the alarm gets active.

Finish parameter input:

Press Button  till display shows *1.on* again.

Now press button  to leave the menu.



ATTENTION

The alarm-outputs are inverted!

This means, that the output will be active when there is no alarm!

Example: You want to control the temperature of a cooling chamber between -20°C and -22°C . Therefore you will have to select -20°C for the turn-on-point 1 "1.on" and -22°C for the turn-off-point 1 "1.off". When the temperature rises above -20°C the device turns its output 1 on, when falling below -22°C the device will turn its output 1 off.

Note: Depending on the inertia of your cooling circuit an overshooting of the temperature may be possible.

Example: You want to have an alarm monitoring for the cooling chamber mentioned above. The alarms should start when the temperature will be rising above -15°C or falling below -30°C .

Therefore you have to select -15°C for the maximum alarm-value "AL.Hi" and -30°C for the minimum alarm-value "AL.Lo".

=> The alarm will be starting after the temperature rises above -15°C and stays above -15°C for the entered delay time or after it had been falling below -30°C and stays below -30°C for the entered delay time.

10.4. Minimum/maximum-alarm (individual or common)

This chapter describes how to adjust the device's alarm boundaries for min-/max-alarm-monitoring. This instruction demands that you selected "AL.F1" or "AL.F2" as output function like it is explained in chapter 8.1.





ATTENTION

The alarm-outputs are inverted!

This means, that the output will be active when there is no alarm!

The display must show **AL.Hi**.

Parameter 	Wert  	Beschreibung
AL.Hi	AL.Lo ... Max. display range	maximum alarm-value
AL.Lo	Min. display range ... AL.Hi	minimum alarm-value
R.dEL	0 ... 9999	Alarm delay. Time [in sec] before the alarm gets active.

Finish parameter input:

Press Button  till display shows **AL.Hi** again.

Now press button  to leave the menu.





Example: You want to have a temperature alarm-monitoring of a greenhouse. The alarm should start when the temperature rises above 50°C or falls below 15°C .

Therefore your settings will be 50°C for the maximum alarm-value "AL.Hi" and 15°C for the minimum alarm-value "AL.Lo".

=> The alarm will be starting after the temperature rises above 50°C and stays above 50°C for the entered delay time or after it had been falling below 15°C and stays below 15°C for the entered delay time.

11. Min-/max-value memory:

The device features a minimum/maximum-value memory. In this memory the highest and lowest performance data is saved.

Button			Note
	Min. value	Press shortly	the device will display "Lo" briefly, after that the min-value is displayed for about 2 sec..
	Max. value	Press shortly	the device will display "Hi" briefly, after that the max-value is displayed for about 2 sec.
 and 	Erase values	Press together for 2 s	the device will display "CLr" briefly, after that the min/max-values are set to the current displayed value.

12. Serial interface

The device features one EASYBus-Interface. You can use the device as a full function EASYBus-device.

The serial interface allows the device to communicate with a host computer. Data polling and data transfer is done in master/slave mode, so the device will only send data on demand. Every device has a unique ID-number that makes exact identification of each device possible. With the help of a software (like EASYBus-Configurator – freeware version available via internet) you are able to re-assign an address to the device.

Additional accessories needed for the interface mode:

- Interface converter EASYBus ↔ PC: e.g. EBW1, EBW3, EBW64

- Software for communication with the device

EBS20M / 60M: 20-/60-channel-software for displaying a measured value.

EASYControl net: universal multi-channel software for real-time-recording and displaying measure-values of a device in ACCESS®-database-format.

EASYBUS-DLL: EASYBUS-developer-package for developing own software. This package features a universal WINDOWS®-Library with documentation and program-examples. The DLL can be used in any usual programming language.

13. Alarm display (only GIR 2002)

If an output function with min-/max-alarm (out = AL.F1) is selected, LEDs will display the min-/max-alarm in case of its appearance.

Min-alarm: LEDs "alarm" and "min" glow

Max-alarm: LEDs "alarm" and "max" glow

If a system-alarm or system-error occurs, it will be handled like a min- and max-alarm. In this case the LEDs "min", "max" and "alarm" will glow. Additionally the error code will be displayed.

14. Error codes

When detecting an operating state which is not permissible, the device will display an error code. The following error codes are defined:

Err.1: Exceeding of the measuring range

Indicates that the valid measuring range of the device has been exceeded.

Possible causes:

- Input signal too high.
- Sensor broken (Pt100 and Pt1000).
- Sensor shorted (0(4)-20mA).
- Counter overflow.

Remedies:

- The error-message will be reset if the input signal is within the limits.
- check sensor, transducer or transmitter.
- check device configuration (e.g. input signal)
- reset the counter.

Err.2: Values below the measuring range

Indicates that the values are below the valid measuring range of the device.

Possible causes:

- Input signal is too low or negative.
- Current below 4mA.
- Sensor shorted (Pt100 and Pt1000).
- Sensor broken (4-20mA).
- Counter underflow.

Remedies:

- The error-message will be reset if the input signal is within the limits.
- Check sensor, transducer or transmitter.
- check device configuration (e.g. input signal)
- Reset the counter.

Err.3: Display range has been exceeded

Indicates that the valid display range (9999 digit) of the device has been exceeded.

Possible causes:

- Incorrect scale.
- Counter overflow.

Remedies:

- The error-message will be reset if the display value is below 9999.
- Reset the counter.
- When happening frequently, check the scale-setting, maybe it was set too high and should be reduced.

Err.4: Values below display range

Indicates that display value is below the valid display range of the device (-1999 digit).

Possible causes:

- Incorrect scale.
- Counter underflow.

Remedies:

- The error-message will be reset if the display value is above -1999.
- Reset the counter
- When happening frequently, check the scale-setting, maybe it was set too low and should be increased.

Err.7: System-error

The device features an integrated self-diagnostic-function which checks essential parts of the device permanently. When detecting a failure, error-message Err.7 will be displayed.

Possible causes:

- Valid operating temperature has exceeded or has fallen below the valid temperature range.
- Device defective.

Remedies:

- Stay within valid temperature range.
- Exchange the defective device.

Err.9: Sensor defective

The device features an integrated diagnostic-function for the connected sensor or transmitter. When detecting a failure, error-message Err.9 will be displayed.

Possible causes: - Sensor broken or shorted (Pt100 or Pt1000).
- Sensor broken (thermo-elements).

Remedies: - Check sensor or exchange defective sensor.

Er.11: Value could not be calculated

Indicates a measuring value, needed for calculation of the display value, is faulty or out of range.

Possible causes: - Incorrect scale.

Remedies: - Check settings and input signal.

Er.12: Invalid value, incorrect configuration

The configuration of the device has been done incorrectly and that it has not been possible to calculate a valid display.

Possible causes: - Incorrect configuration of the device.

Remedies: - Check configuration of device.

15. Special functions (optionally): Tare

Optionally the device may have a tare function. The display value can be set to 0 by means of this function. The display then is calculated relatively to the tare value.

Setting the tare function: press  shortly the display value will be set to 0

Clearing the tare function: press  for ~2 seconds the current measuring value is displayed again.

The flashing LED "S2" is indicating an active tare function.



Calling the tare function at a current measuring value of 0 is not possible. If a tare function is already active when pressing the key 4 at display value 0, then the tare function will be cleared.

16. Decommissioning, reshipment and disposal**16.1. Decommissioning**

Always disconnect the device before from its supply before decommission (e.g. at fuse). Valid general safety requirements shall be observed.

Please also make sure that connected Loads are disconnected also and are in a safe state.

16.2. Reshipment and disposal

All devices returned to the manufacturer have to be free of any residual of measuring media and other hazardous substances.

Measuring residuals at housing or sensor may be a risk for persons or environment



Use an adequate transport package for reshipment, especially for fully functional devices. Please make sure that the device is protected in the package by enough packing materials.

Add the completed reshipment form of the GHM website

<http://www.ghm-messtechnik.de/downloads/ghm-formulare.html>.



The device must not be disposed in the unsorted municipal waste! Send the device directly to us (sufficiently stamped), considering the above if it should be disposed. We will dispose the device appropriate and environmentally sound.

17. Specification

Absolute maximum ratings: see chapter 5.3. (Connection data)

Measuring inputs: Standard inputs for

Input type	Signal I	Range	Resolution	Note
Standard-voltage-signal	0 – 10 V	0 ... 10 V		Ri ≥ 200 kOhm
	0 – 2 V	0 ... 2 V		Ri ≥ 10 kOhm
	0 – 1 V	0 ... 1 V		Ri ≥ 10 kOhm
	0 – 50 mV	0 ... 50 mV		Ri ≥ 10 kOhm
Standard-current-signal	4 – 20 mA	4 ... 20 mA		Ri = ~ 125 Ohm
	0 – 20 mA	0 ... 20 mA		Ri = ~ 125 Ohm
RTD probes	Pt100	-50.0 ... +200.0 °C (-58.0 ... +392.0 °F)	0.1 °C / °F	3-wire-connection max. perm. line resistance: 20 Ohm
		-200 ... +850 °C (-328 ... +1562 °F)	1 °C / °F	
	Pt1000	-200 ... +850 °C (-328 ... +1562 °F)	1 °C / °F	2- wire-connection
Thermocouple probes	NiCr-Ni (type K)	-70.0 ... +250.0 °C (-94.0 ... +482.0 °F)	0.1 °C / °F	
		-270 ... +1372 °C (-454 ... +2502 °F)	1 °C / °F	
	Pt10Rh-Pt (type S)	-50 ... +1750 °C (-58 ... +3182 °F)	1 °C / °F	
	NiCrSi-NiSi (type N)	-100.0 ... +300.0 °C (-148.0 ... +572.0 °F)	0.1 °C / °F	
		-270 ... +1350 °C (-454 ... +2462 °F)	1 °C / °F	
	Fe-CuNi (type J)	-70.0 ... +300.0 °C (-94.0 ... +572.0 °F)	0.1 °C / °F	
		-170 ... +950 °C (-274 ... +1742 °F)	1 °C / °F	
	Cu-CuNi (type T)	-70.0 ... +200.0 °C (-94.0 ... +392.0 °F)	0.1 °C / °F	
		-270 ... +400 °C (-454 ... +752 °F)	1 °C / °F	
	Frequency	TTL-Signal	0 Hz ... 10 kHz	0.1 mHz
Switching contact NPN		0 Hz ... 3 kHz	0.1 mHz	An internal pull-up-resistor (~7 kOhm to +3.3V) is connected automatically.
Switching contact PNP		0 Hz ... 1 kHz	0.1 mHz	An internal pull-down-resistor (~7 kOhm to GND) is connected automatically.
Flow rate	TTL-Signal, Switching contact NPN, PNP	see frequency	see frequency	
Rotation	TTL-Signal, Switching contact NPN, PNP	0 ... 9999 U/min	0.001 U/min	Pre-scaling-factor (1-1000), Pulse-frequency: max. 600000 p./min. *
Up/Downwards- Counter	TTL-Signal, Switching contact NPN, PNP	0 ... 9999 with scaling factor: 9 999 000		Pre-scaling-factor (1-1000) Pulse-frequency: max. 10000 p./sec. *
	Counter reset input	--		Reset: R < 1 kOhm Enable: R > 100 kOhm

* with switching contact accordingly to frequency input lower values may occur

Display range: (voltage-, current and frequency-measurement)
-1999 ... 9999 digits, initial value, terminal value and decimal point position arbitrary. Recommended range: < 2000 Digit

Accuracy: (at nominal temperature)

Standard-signals: < 0.2% FS \pm 1Digit (0 – 50mV: < 0.3% FS \pm 1Digit)

RTD: < 0.5% FS \pm 1Digit

Thermocouples: < 0.3% FS \pm 1Digit (type S: < 0.5% FS \pm 1Digit)

Frequency: < 0.1% FS \pm 1Digit

Point of compensation: \pm 1°C \pm 1Digit (at nominal temperature)

Temperature drift: < 0.01% FS / K (Pt100 – 0.1 °C: < 0.015% FS / K)

Measuring freq.: approx. 100 measures / sec. (standard-signal) or
approx. 4 measures / sec. (temperature-measurement) or
approx. 100 measures / sec.
(frequency, rpm at $f \geq 100$ Hz) or $1/f + 15$ msec (at $f < 100$ Hz)

Display: approx. 13 mm height, 4-digit red LED-display

Operating: 4 push-buttons or by interface

Interface: EASYBus-interface, electrically isolated

Busload: 1 EASYBus-device

Transmitter supply: 24 V_{DC} \pm 5%, 22 mA, electrically isolated
or corresponding to designation on the label on the housing

Outputs: depending on design model

Switching outputs:^{*2} 2 volt-free Relay-outputs (standard)
Optionally: control output for solid-state relay
or corresponding to designation on the label on the housing

Output 1: ^{*3} Relays: make contact, breaking capacity: max 5 A (ohmic load), 250 V_{AC}
(at option HLR1: control output for solid-state relay
control voltage: \sim 6 V_{DC} / max. 15 mA)

Output 2: Relays: change-over contact, breaking capacity: max 10 A (ohmic load), 250 V_{AC}
(at option HLR2: control output for solid-state relay
control voltage: \sim 6 V_{DC} / max. 15 mA)

Response time: \leq 25 ms for standard signals
 \leq 0.5 s for temperature, frequency ($f > 4$ Hz)

Functions: 2-point, 3-point, 2-point with alarm, min-/max-alarm common or individual and
3-point with alarm ^{*6}

Switching points: arbitrary

Analog output: ^{*4 *5} 0-20 mA and 4-20 mA (AAG020/..) or 0-10 V (AAG010/..
or corresponding to designation on the label on the housing

Scaling: arbitrary

Accuracy: 0.3 % FS

Zero point offset: 30 mV at 0..10 V, 60 μ A at 0..20 mA

Min. permissible load: 1000 Ohm (at AAG010/..)

Max. perm. burden: 300 Ohm (at AAG020/..)

Output options: R3, H3 or N3:

Additional 3rd output for alarm (enable the output function 3-point with alarm)

R3	Output 3:	volt-free relay output (change-over contact)
	Switching power:	Max 1 A / 30 V _{DC} or 40 V _{AC}
H3	Output 3:	control output for solid-state relay
	Control voltage:	\sim 14 V _{DC} / max. 15 mA
N3	Output 3:	electrical isolated NPN switching output, switching to –U _a
	Switching power:	Max 1 A / 30 V _{DC}
	Auxiliary voltage:	14 V _{DC} / max. 15 mA

Power supply: 230 V_{AC} ($\pm 10\%$), 50/60 Hz (standard)
or corresponding to designation on the label on the housing

Isolation: Overvoltage category II acc. EN 61010-01

Consumption: approx. 4 VA (analog output options approx. 5.5 VA)

Nominal temp.: 25 °C

Ambient conditions:

Operating ambient: -20 to +50 °C

Relative humidity: 0 to 80 %RH (non condensing)

Storage temp.: -30 to +70 °C

Max elevation: 5000 m above sea level

Housing: Panel mounting with brackets

Panel cut-out: 90.5^{+0.5} x 43.0^{+0.5} mm (B x H)

Dimensions: 96 x 48 mm (front dimensions W x H).

Installation depth: approx. 115 mm (incl. screw-in/plug-in clamps)

Connection: screw-in/plug-in clamps

Cross-sections:	Signal terminals	
	0.14 to 1.5 mm ²	single-wire, fine-wire with sleeve (sleeves with insulating enclosures max. 1 mm ²)
	Supply terminals	
	0.14 to 2.5 mm ²	single-wire, fine-wire with sleeve (sleeves with insulating enclosures max. 1,5 mm ²)

Protection data

Prot. class front: IP 54 acc. EN 60529, with sealing GGD4896: IP 65

Prot. class housing and connections:
IP 20 acc. EN 60529

Contamination class: 2 acc. EN 61010-01

Directives and standards: The instruments confirm to following European Directives:

2014/35 EU Low Voltage directive

2014/30/EU EMC Directive

2011/65/EU RoHS

Applied harmonized standards:

EN 61326-1 : 2013 emissions level: class B
emi immunity according to table 2
Additional fault: <1 %

EN 61010-1 : 2011

*2 = not available at GIA 2000

*3 = not available at GIR 2002 with option AA1 or AV1

*4 = only available with option AA1 or AV1

*5 = only available with option AA3 or AV3

*6 = only available with option R3, H3 or N3

